

Ultrafly D/13/32

Brushless, Sensorless Motor



A Bargain for Quality and Performance.

Designed for gear drive applications, Ultrafly's D/13/32 brushless, sensorless "outrunner" motor is a unique and affordable option for park flyer models weighing below 1kg (2.2lb). Its high-quality construction and precise CNC tooling enable this motor to operate at higher RPM without serious vibration. The D/13/32 fits in many 300/400 size gearboxes, and features a shaft diameter and screw holes comparable to a 400 motor.

Used with the appropriate gear ratio, the D/13/32 can turn propellers ranging from 6 inch to 11 inch diameter. You can power it with NiCd or NiMH batteries having 7-10 cells, or with a 2-3 cell Li-Po battery. See the motor application reference table below for more details.

Specifications

- Shaft Diameter: 2.3mm
- Shaft Length: 12mm
- Motor Diameter: 23.5mm
- Motor Length: 43mm
- Motor Weigh: 42g (1.42oz)
- Distance of Mounting Holes: 16mm & 17mm
- Mounting Screw: M3x3mm
- Maximum Input Power: 160watt
- Maximum RPM: 40,000
- Maximum Operating Temperature: 100°C

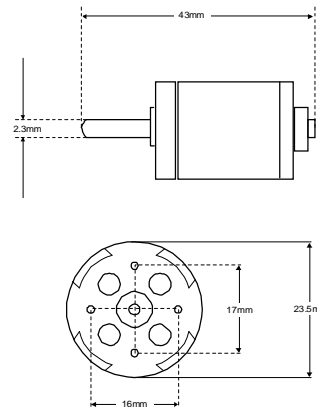

D/13/32 Brushless Motor Application Reference Table

Airplane Type	Battery	Gear Ratio	Propeller
250-340g 3D models	3S Lipo	3 to 1	APC 10x4.7SF
250-340g 3D models	3S Lipo	2.33 to 1	APC 8x3.8SF
340g-500g 3D models	3S Lipo	3.9 to 1	APC 11x4.7SF
340g-500g 3D models	12V NiMH	3.9 to 1	APC 11x4.7SF
350-450g Sports Models	9.6V NiMH	3 to 1	APC 9x6SF or 8x8E
450-600g Sports Models	12V NiMH	3 to 1	APC 9x6SF or 8x8E
450-600g Sports Models	3S Lipo	3 to 1	APC 9x6SF or 8x8E
400-500g Speedy models	9.6V NiMH	2.33 to 1	APC 7x5E
500-600g Speedy models	12V NiMH	2.33 to 1	APC 7x5E
500-600g Speedy models	3S Lipo	1.93 to 1	APC 6x5.5E
600-750g Hi-Wing Trainers	9.6V NiMH	3 to 1	APC 9x6SF or 10x4.7SF
750-1000g Hi-Wing Trainers	12V NiMH	3 to 1	APC 9x6SF or 10x4.7SF
750-1000g Hi-Wing Trainers	3S Lipo	3 to 1	APC 9x6SF or 10x4.7SF
650-800g Gliders	9.6 NiMH	3 to 1	9x5 or 9x6 folding prop
750-1000g Gliders	12V NiMH	4 to 1	10x6 folding prop
750-1000g Gliders	3S Lipo	4 to 1	10x6 folding prop

Application on Actual Model

GWS Warbirds 400-500g	9.6-12VNiMh	3 to 1	APC 9x6SF or 8x8E
GWS Estarter, Beaver, Big stick	8.4-9.6V NiMh or 2S Lipo	3 to 1	GWS 9x6, 10x4.7 or APC 9x6SF, 10x4.7SF
Ultrafly PC-9, Cessna 182	9.6V-12VNiMh	3 to 1	APC 9x6SF or 8x8E
Ultrafly Extra 300S	12VNimh or 3S Lipo	3 to 1	APC 9x6SF

Cautions:

Speed Control: You must use a brushless, sensorless speed control.

Cooling: You must provide proper cooling to avoid exceeding the 100°C limit. Overheating will damage the magnets and windings, and is not covered under warranty.

Over current: Please use a current meter to control the battery cell count and the propeller size. When changing propeller size or battery type, you must measure the current. You must limit current to the specifications above, or less, to avoid damage to the motor. Reduce prop size or battery cell count to reduce current.

Max input watt: The structural design of every motor will limit its heat dissipation. Watt input is proportional to heat generated. The maximum watt input for D series is 160 watts. Do not exceed this limit or you may burn out the motor.

Rotation: Switch any two of the three wires between the speed controller and motor to reverse motor direction. NEVER reverse polarity from battery to speed controller.

Limited Warranty:

Ultrafly brushless motors have a one-year, limited warranty from the date of purchase. All motors are guaranteed to be free from manufacturing defects for one year. The warranty does not cover over-current, over-temperature, or crash damage. You must properly cool the motor and keep the current and input wattage within specifications. Improper use of the motor can be determined in service and will not be covered in the warranty.

All warranty issues shall be handled by your dealer first. If necessary, you may also contact us for warranty issues. Send mail to service@ultraflymodel.com or contact the distributor in your country.

