

# TEAM LOSI MINI-T PRO

1/18TH SCALE ARR PRO VERSION OF  
THE CHAMPIONSHIP WINNING XXX-T

## Operations Manual

### Introduction

Thank you for choosing the Mini-T Pro from Team Losi Sport. This model requires you to install the Radio gear and fill the shocks with fluid. This guide contains these and the basic instructions for operating your new Mini-T Pro. It is critical that you read all of the instructions and all accompanying printed material in order to operate your model correctly and avoid unnecessary damage. Please take a moment to look them over before building the model.



Copyright 2004 Team Losi  
A Division of Horizon Hobby Inc.  
800-0249  
RT 11-04



Visit [www.modelflight.com.au](http://www.modelflight.com.au) for more information and spare parts online.

## Safety Precautions

This is a sophisticated radio controlled model that must be operated with caution and common sense.

Failure to operate your Mini-T Pro in a safe and responsible manner could result in damage to the model and property. The Mini-T Pro is not intended for use by children without direct supervision. Team Losi and Horizon Hobby shall not be liable for any loss or damages, whether direct, indirect, special, incidental, or consequential, arising from the use, misuse, or abuse of this product or any product required to operate it.

- This model is controlled by a radio signal that is subject to interference from many sources outside your control. This interference can cause momentary loss of control so it is advisable to always keep a safety margin in all directions to avoid collisions.
- Always operate your model in an open area away from cars, traffic and people
- Never run out into the street for any reason.
- Never run your Mini-T Pro with low transmitter batteries
- Carefully follow the directions and warnings for this and any optional support equipment (chargers, rechargeable battery packs, etc.) that you use.
- Keep all chemicals, small parts and anything electrical out of the reach of children.

## Required Equipment

2 Channel Radio System with Receiver  
Micro size Servo

Electronic Speed Controller  
Battery and Charger

## Radio Installation

You will need a receiver, electronic speed control (ESC), and micro steering servo to complete your Mini-T Pro. If you do not already have these we suggest you use one of the newer smaller receivers and ESC's as it will be easier to fit these in the space available. All of the popular radio manufactures as well as Novak, GM Racing and LRP offer these items. We show mounting four of the most popular steering servos. Please note that in most cases we suggest the use of a servo saver as noted.

- 1) Cut a piece of double sided mounting tape to fit the bottom of both the receiver and ESC. Remove the paper backing from one side and apply to the bottom – Do Not remove the remaining backing yet!
- 2) Test position the receiver and ESC on the top surface of the battery plate checking for adequate clearance and convenient access for all wiring. Mark or note these positions before proceeding.
- 3) Remove the protective backing from the mounting tape on the receiver and ESC. Carefully mount them on the battery plate.

## Sample picture of electronics installed in the Mini-T Pro



## Final Connections

Follow the radio manufactures instructions when making the final electronic connections. Specifically, the orientation of the color-coded wires in the various plugs where they plug into the receiver. If you plan on removing the wires attached to the motor mark the endbell with a "+" at the red wire and "-" at the black wire for future reference. Follow the radio instructions to set the proper steering and throttle movement. Follow the instructions included with the ESC for correct operation.

## Recommended Servos



Airtronics  
94091Z

HiTEC  
HS-55

JR Propo  
S241MG

Expert Electronics  
SL110

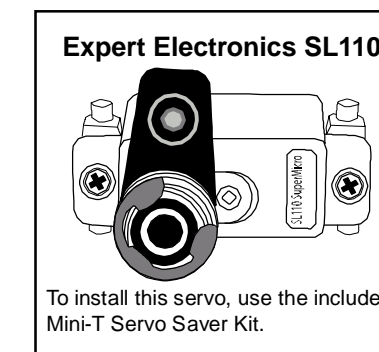
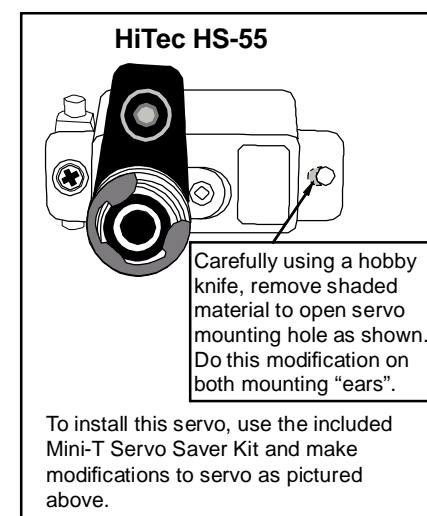

## Installing the Servo

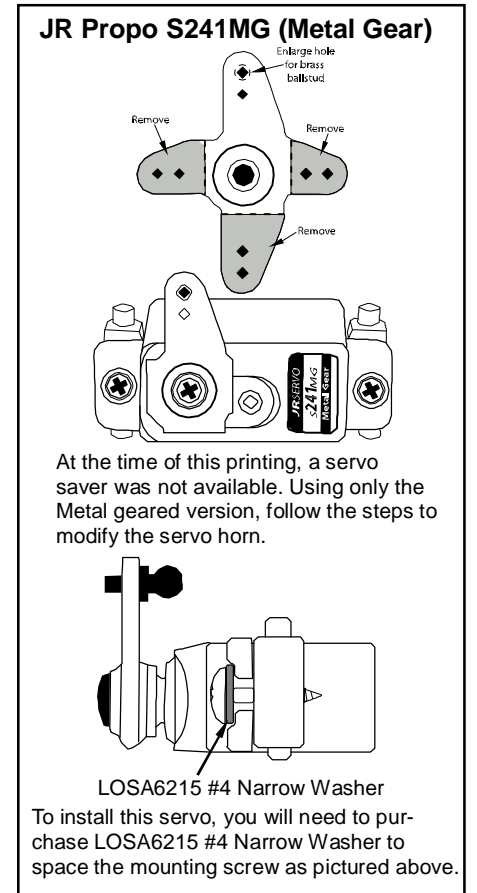
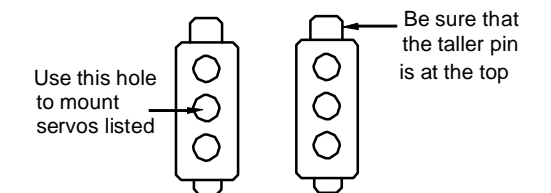

Install the Servo into the Chassis as shown in **Figure 1**. Insert the pins on the Servo Mounting Post into the holes in the Chassis. Move the Servo Posts slightly until both the left and right Posts are inserted in the holes in the Chassis. Next place the Chassis Brace on top of the Servo. The pins from both Servo Mounting Posts should line up with the holes on the Servo Brace. If they do not, move the Posts slightly until the pins fit into the holes. Secure the Brace to the Chassis with the four Phillips head screws as shown in **Figure 2**.

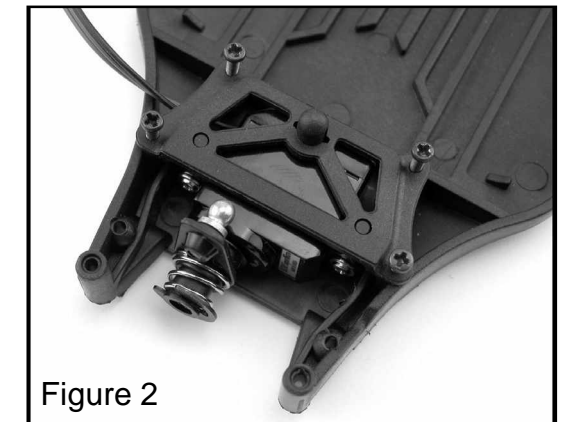
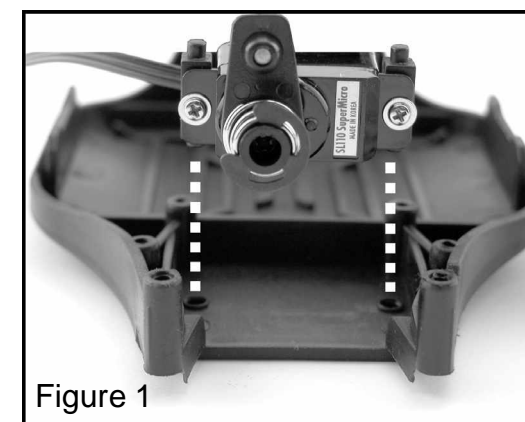

## Making Adjustments

The following are simple adjustments and easily maintained settings that will assure proper operation and performance. Since the Mini-T Pro comes from the factory with optimum settings, we suggest first-time R/C drivers leave these as they are and simply maintain them as necessary. Only after gaining experience should new drivers try experimenting with different settings.

## Chassis Tuning

The Mini-T Pro has several adjustments available to you for tuning the performance for your needs. Although there are multiple shock positions and camber link locations provided, as noted above we have built the model with the best overall settings. The following are simple adjustments and easily maintained settings that will assure proper operation and performance. It is advised that when making any adjustment you do so in small increments and always check for other parts of the chassis that are affected.

## Steering Rate

Your transmitter may be equipped with a steering rate control. This feature allows you to adjust the amount the front tires move when you turn the steering wheel. This is really helpful when you are on slick as well as high traction surfaces. If your Mini-T Pro turns too sharply and/or spins out easily, try decreasing the steering rate. For sharper or additional steering, try increasing the steering rate.

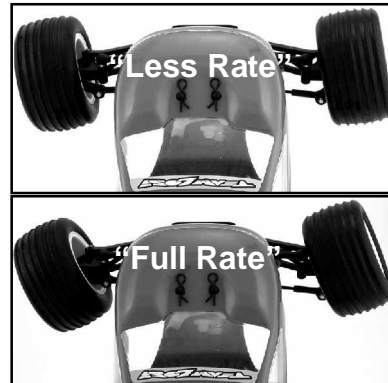

## Camber

Camber is the angle of the tires to the racing surface when viewed from the front or rear of the truck. You want to keep both the front and rear tires straight up and down or leaning in at the top very slightly. If you are running on carpet or similar high traction surfaces you may find leaning them in a bit more helps. This adjustment is made with the turnbuckle links that extend from the front or rear bulkhead to the spindle carrier or rear hub. The Mini-T Pro is equipped with adjustable Titanium Turnbuckles that if turned one way (using the provided wrench) get shorter and if turned in the opposite direction get longer. Making these shorter increases the camber and lean-in of the tire while making them longer decreases the camber.



## Toe-In

This is the relationship of the left and right side tires to one another. Ideally, you want the front of the tires to be pointed inward toward each other just slightly when viewed from above. This makes the model track straight and stable. This is controlled with the adjustable steering rods on either side. As you make them longer you will increase the toe-in and vice versa.

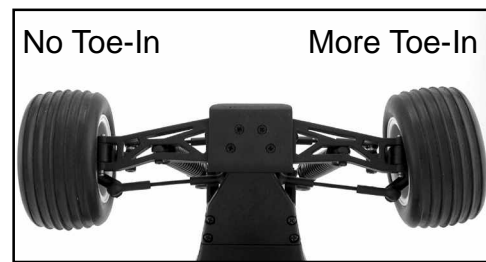

## Ride Height

This is the height the chassis sits and runs at. There are spring spacers included with the Mini-T Pro that, when installed between the shock top and spring, will increase the pre-load on the spring and raise the chassis. You may want to try this when running on extremely rough surfaces.

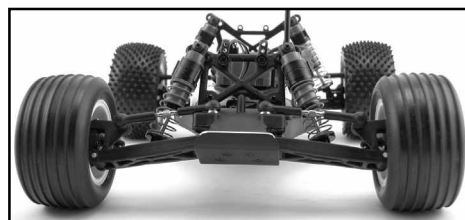

More Pre-load

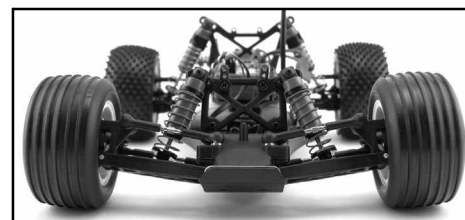

Less Pre-load

## Setting The Gear Mesh

The motor screws should be slightly loose. Slide the motor forward allowing the pinion gear to mesh with the spur gear. Snug (not tight) the bottom motor screw and try rocking the spur back and forth. There is a slight bit of movement before the motor is forced to turn over. If not, pull the top of the motor back slightly and recheck, there should be a slight bit of movement. If there is too much slop between the gears push the top of the motor forward. When set properly the wheels can be spun forward freely with very little noise. Make sure to tighten both motor screws and replace the gear cover before running.



## NEVER Let your differential slip!

Follow the instructions below for proper operation and adjustment

## Ball Diff/Slipper Adjustment Instructions

Always make sure your slipper will slip before the diff, as this will diminish the load on the differential and transmission. The diff should never slip. Hold the right tire and the spur gear in one hand and rotate the left tire. As you rotate the left tire, the slipper plate, and shaft should turn. This means the slipper is slipping before the differential. If the slipper shaft is not turning, your differential is slipping. You must either tighten the diff and/or loosen the slipper and recheck. To tighten the diff, remove the left side driveshaft and use a .050" Allen wrench and turn the diff screw clockwise in one-hour increments and recheck as noted above until it no longer slips. Any time you tighten the slipper you should check the diff as noted and tighten if necessary.

## Slipper Adjustments

The Mini-T Pro is equipped with a Double Disk slipper device that offers both traction control and protection for the transmission. The slipper is primarily used to help absorb sudden impacts on the drive train due to landing big jumps or when using more powerful aftermarket motors and/or battery packs. Additionally, it can be used to smooth out the flow of power to the rear wheels and limit wheel spin when running on extremely slick surfaces. Adjustment is made by removing the access plug in the gear cover and turning the 3mm adjustment nut clockwise (to the right) to reduce the slip or counterclockwise (to the left) to increase the slip (Figure 3). When adjusted properly, you should be able to hold the rear tires firmly and barely be able to push the spur gear forward with your thumb (Figure 4). To track test, turn the Mini-T on and place it on the ground. As you push it backwards allowing it to roll freely, punch the throttle. The slipper should slip no more than an inch or two as it accelerates. With a 5 or 6 cell battery pack it should slip just a little. Make sure you replace the gear cover before running.

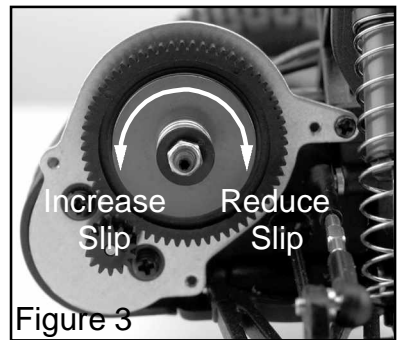

Figure 3

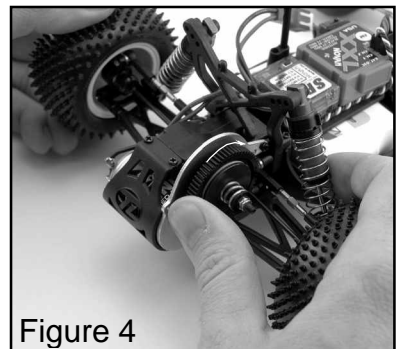
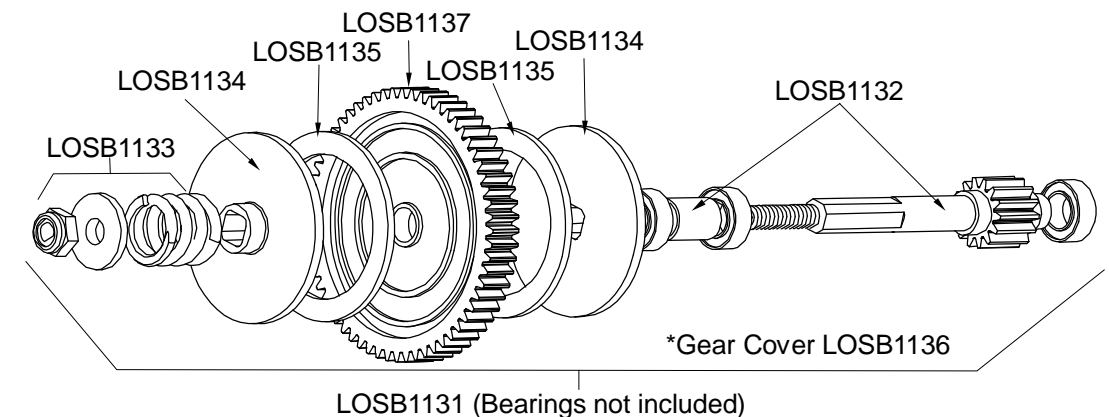
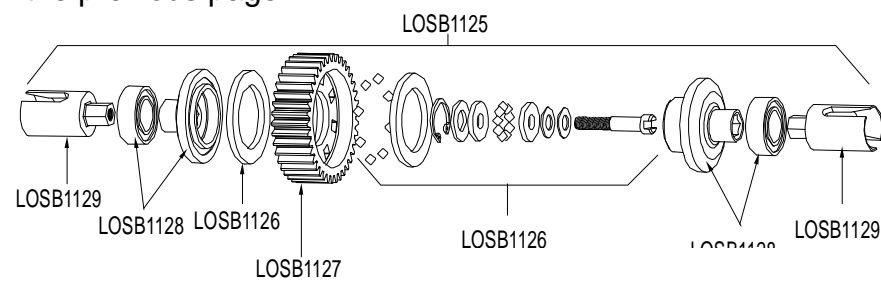
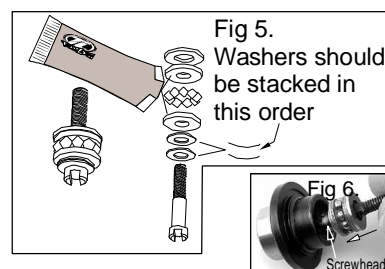

Figure 4



## Rebuilding The Ball Differential

**1)** Remove your ball differential from your tranny. **2)** Remove left outdrive cup and loosen diff adjusting screw with a small flathead screw driver or a .050 allen wrench. Remove right side outdrive assembly. **3)** Clean diff gear, diff rings and balls. If needed, replace worn parts and lube with Losi Silicone Diff Grease LOSA3065 **4)** Remove "C" clip from male outdrive half and carefully remove diff thrust assembly. **5)** Clean all thrust components and replace if needed. Reassemble thrust components (**Figure 5**). **6)** Install thrust assembly into male outdrive as shown in (**Figure 6**). Install a new "C" Clip. **7)** While holding male outdrive half install large diff washers, diff gear with balls. **8)** Apply thread lock to diff screw and reassemble diff. Carefully bottom the diff screw out and back the screw out 1/16th of a turn. Your diff is now set. **9)** Reassemble tranny. **10)** Refer to Ball Diff/Slipper Adjustment Instructions on the previous page.



## Filling and Maintaining the Racing Shock Absorbers

### Filling and Bleeding Your Shocks

**1.** Remove the spring by pushing the lower spring cup away from the shock end and sliding it out, off of the shaft.

**2.** Unscrew the shock cartridge (7mm) and remove the shaft/cartridge/piston assembly.

**3.** Use the included Team Losi 20 weight silicone fluid to fill the shock body to the bottom of the internal threads.

**4.** With the shaft half way through the cartridge, insert the piston into the fluid and start to thread the cartridge into the body approximately two turns.

**5.** With the cartridge loose, and holding the shock with the shaft up, push the shaft all the way in, allowing the excess fluid to escape.

**6.** Tighten the cartridge down (about 1/2 to 1 turn) **being careful not to stripe the threads.**

**7.** Move the shaft back and forth through its normal range of movement. There should be a constant resistance. If there is a greater resistance as the shaft is fully compressed, there is too much oil and it needs to be re-bled by following step #5. If there is less resistance at any point, there is not enough oil and you need to repeat steps #2 through #5. Otherwise, replace the spring and spring cup.

**NOTE:** If leakage occurs where the cartridge seals to the shock body, you should replace the thin circular seal between the shock cartridge and shock body.

### Changing the Shock Cartridge

**1.** Remove the cartridge/assembly from the shock.

**2.** Remove the shock piston and the small e-clips above and below it.

**3.** Remove the old cartridge and slide the new cartridge onto the shaft. Replace the e-clips and shock piston. Put a new seal onto the cartridge and follow steps #3 through #6 above.

### Changing the Pistons

**1.** Remove the cartridge/assembly from the shock.

**2.** Remove the e-clip from above the piston at the end of the shock shaft.

**3.** Replace the piston with the one of your choice (small, medium or large hole).

**4.** Replace the e-clip and follow steps #3 through #6 above.

**NOTE:** Always replace front or rear pistons in pairs-never just one piston.

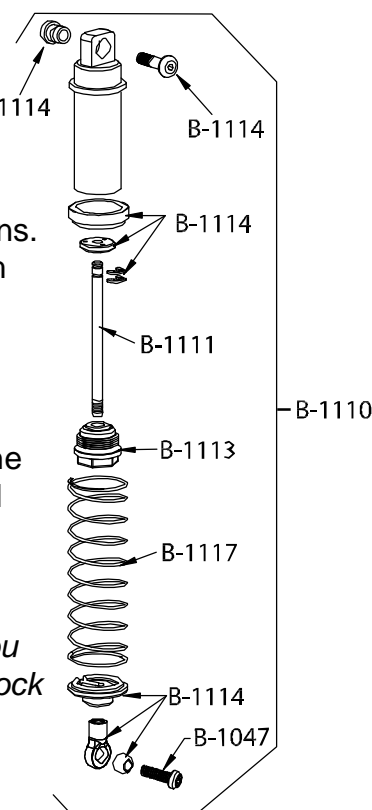
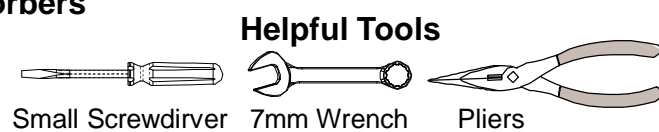

## Battery Placement

The Mini T Pro features a choice of battery positions. In the "Back" position, the Mini-T Pro will have a bit more traction and will jump nose high with less steering. In the "Forward" position, the Mini-T Pro will have more steering and jump with the nose down. Try playing with the different positions to find the best handling for your track.



Battery Position "Back"



Battery Position "Forward"



## Body Painting

Before you start, please note the following tips. Use only paint that is designed for polycarbonate bodies or it may chip, flake, or cause the body to crack. Use quality masking tape (3M, Scotch, etc) or commercially available pre-cut masks (XXX Main, Parma, etc) – do not use clear "sealing" tape, as it is very difficult to remove. Always try to apply darker colors first. Backing a lighter color with white will produce a brighter appearance. Back white with a coat of silver (unless it is the last color applied) to prevent other colors from bleeding through. Always allow plenty of time for the paint to dry before pulling the tape or applying another color.

**1)** Wash the inside of the body with a little liquid detergent and warm water. **2)** After drying thoroughly, position the pre-cut window masks (supplied) to the inside of the body and firmly press them down for good adhesion. **3)** Use masking tape or pre-cut masks (not supplied) to the inside of the body to produce the pattern you desire. Try to tape the body so you will apply the darker colors first following the tips noted above. **4)** Follow the paint manufacturer's instructions when applying the paint being careful not to allow it to build up in any one spot. Remember to allow plenty of drying time between colors. **5)** Remove the window masks and protective film from the outside of the body. Use R/C Body cleaner or Isopropyl Alcohol (do not use any hot solvents) to clean up any overspray etc. on the outside of the body if any, before applying the stickers.



# Mini-T Pro Trouble Shooting Guide

Doesn't operate	Battery not charged or plugged in No crystal in receiver  No crystal in transmitter  Receiver switch not "on" Transmitter not "on" or low battery	Charge battery / plug-in Check and replace if necessary Check and replace if necessary Turn on receiver switch Turn on / replace batteries
Motor runs but rear wheels don't move	Pinion not meshing with spur gear Pinion spinning on motor shaft Slipper too loose Differential slipping Drive pin in axle missing	Adjust pinion/spur mesh replace pinion gear on motor Check & adjust slipper Adjust / check differential Check & replace
Steering doesn't work	Servo plug not in receiver Servo damaged	Check if plug in / all the way Replace or repair servo
Won't turn one direction	Servo gears damaged	Replace servo gears
Motor doesn't run	Motor plugs loose Motor wire broken ESC damaged	Plug-in completely Repair or replace as needed Check with manufacture
ESC gets hot	Motor over geared Driveline bound up	Put smaller pinion on motor Check wheels & trans for binds
Poor run time and/or sluggish acceleration	Batteries weak or low Ni-Cad pack not fully charged Charger not allowing full charge  Slipper slipping too much Differential slipping Motor worn out Driveline bound up	Check / replace battery pack Recharge Try another charger/power source Check/adjust slipper & diff Tighten immediately Replace motor Check wheels & trans for binds
Poor range/glitches	Transmitter battery low  Transmitter antenna loose Battery low in truck Loose plugs or wires	Check & replace as necessary Check & tighten Replace or recharge Check motor and power plugs
Slipper won't adjust	Drive pin missing in shaft Slipper pads worn out	Replace drive pin Replace & adjust slipper