

## FOUR CYCLE ENGINE

### OWNER'S INSTRUCTION MANUAL

It is of vital importance, before attempting to operate your engine, to read the general **•SAFETY INSTRUCTIONS AND WARNINGS•** section on pages 2-6 of this booklet and to strictly adhere to the advice contained therein.

- Also, please study the entire contents of this instruction manual, so as to familiarize yourself with the controls and other features of the engine.
- Keep these instructions in a safe place so that you may readily refer to them whenever necessary.
- It is suggested that any instructions supplied with the aircraft, radio control equipment, etc., are accessible for checking at the same time.

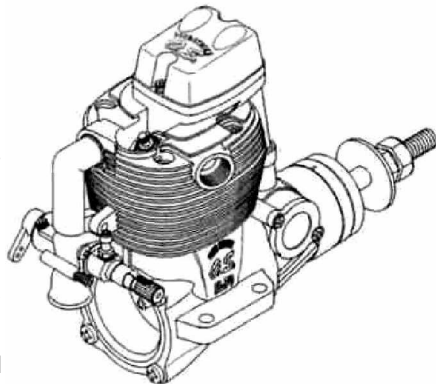

---

## CONTENTS

### SAFETY INSTRUCTIONS AND WARNINGS

ABOUT YOUR O.S. ENGINE ----- 2-6

ENGINE CONSTRUCTION ----- 7

NOTES WHEN APPLYING AN ELECTRIC STARTER ---- 8

INTRODUCTION ----- 9

BEFORE STARTING ----- 10-13

ENGINE PARTS NAME-----14

INSTALLATION ----- 15-16

SILENCER & EXHAUST HEADER PIPE INSTALLATION ----- 17

FUEL TANK & LINES ----- 18-20

THROTTLE LINKAGE, NEEDLE-VALVE EXTENSION ----- 21

PROPELLER & SPINNER ATTACHMENT ---- 22-23

GLOWPLUG -----24

TYPE 60W CARBURETOR, STARTING ----- 25-27

RUNNING -IN, CARBURETOR ----- 27-30

CARBURETOR AIR-BLEED ADJUSTMENT ----- 31

TROUBLE SHOOTING WHEN THE  
ENGINE FAILS TO START----- 32-33

VALVE ADJUSTING----- 34

HOW TO SET THE CAMSHAFT TIMING ----- 35

CARE AND MAINTENANCE ----- 36-37

ENGINE EXPLODED VIEWS & PARTS LIST ----- 38-39

CARBURETOR EXPLODED VIEWS  
& PARTS LIST ----- 40-41

GENUINE PARTS & ACCESSORIES -----42-43

THREE VIEW DRAWING ----- 44

## SAFETY INSTRUCTIONS AND WARNINGS ABOUT YOUR O.S. ENGINE

Remember that your engine is not a "toy", but a highly efficient internal-combustion machine whose power is capable of harming you, or others, if it is misused.

As owner, you, alone, are responsible for the safe operation of your engine, so act with discretion and care at all times.

If at some future date, your O.S. engine is acquired by another person, we would respectfully request that these instructions are also passed on to its new owner.

The advice which follows is grouped under two headings according to the degree of damage or danger which might arise through misuse or neglect.



### WARNINGS

These cover events which might involve serious (in extreme circumstances, even fatal) injury.



### NOTES

These cover the many other possibilities, generally less obvious sources of danger, but which, under certain circumstances, may also cause



## WARNINGS

- Never touch, or allow any object to come into contact with, the rotating propeller and do not crouch over the engine when it is running.



- A weakened or loose propeller may disintegrate or be thrown off and, since propeller tip speeds with powerful engines may exceed 600 feet (180 metres) per second, it will be understood that such a failure could result in serious injury, (see 'NOTES' section relating to propeller safety).

- Model engine fuel is poisonous. Do not allow it to come into contact with the eyes or mouth. Always store it in a clearly marked container and out of the reach of children.



- Model engine fuel is also highly flammable. Keep it away from open flame, excessive heat, sources of sparks, or anything else which might ignite it. Do not smoke or allow anyone else to smoke, near to it.



- Never operate your engine in an enclosed space. Model engines, like automobile engines, exhaust deadly carbon-monoxide. Run your engine only in an open area.

- Model engines generate considerable heat. Do not touch any part of your engine until it has cooled. Contact with the muffler (silencer), cylinder head or exhaust header pipe, in particular, may result in a serious burn.





## NOTES

- This engine was designed for model aircraft. Do not attempt to use it for any other purpose.
- Mount the engine in your model securely, following the manufacturers' recommendations, using appropriate screws and lock-nuts.
- Be sure to use the silencer (muffler) supplied with the engine. Frequent exposure to an open exhaust may eventually impair your hearing. Such noise is also likely to cause annoyance to others over a wide
- If you remove the glowplug from the engine and check its condition by connecting the battery leads to it, do not hold the plug with bare fingers. Use an appropriate tool or a folded piece of cloth.
- Install a top-quality propeller of the diameter and pitch specified for the engine and aircraft. Locate the propeller on the shaft so that the curved face of the blades faces forward-i.e. in the direction of flight. Firmly tighten the propeller nut, using the correct size wrench.



## NOTES

- Always check the tightness of the propeller nut and retighten it, if necessary, before restarting the engine, particularly in the case of four-stroke-cycle engines. If a safety locknut assembly is provided with your engine, always use it. This will prevent the propeller from flying off in the event of a "backfire", even if it loosens. Also, check the tightness of all the screws and nuts before restarting the engine.
  - If you install a spinner, make sure that it is a precision made product and that the slots for the propeller blades do not cut into the blade roots and weaken them.
  - Preferably, use an electric starter. The wearing of safety glasses is also strongly recommended.
  - Discard any propeller which has become split, cracked, nicked or otherwise rendered unsafe. Never attempt to repair such a propeller: destroy it. Do not modify a propeller in any way, unless you are highly experienced in tuning propellers for specialized competition work such as pylon-racing. Take care that the glow plug clip or battery leads do not come into contact with the propeller. Also check the linkage to the throttle arm. A disconnected linkage could also foul the propeller.
- After starting the engine, carry out any needle-valve readjustments from a safe position behind the rotating propeller. Stop the engine before attempting to make other adjustments to the carburetor.



## NOTES

- Adjust the throttle linkage so that the engine stops when the throttle stick and trim lever on the transmitter are fully retarded. Alternatively, the engine may be stopped by cutting off the fuel supply. Never try to stop the engine physically.
- Take care that loose clothing (ties, shirt sleeves, scarves, etc.) do not come into contact with the propeller. Do not carry loose objects (such as pencils, screwdrivers, etc.) in a shirt pocket from where they could fall through the propeller arc.
- Do not start your engine in an area containing loose gravel or sand. The propeller may throw such material in your face and eyes and cause injury.
- For their safety, keep all onlookers (especially small children) well back (at least 20 feet or 6 meters) when preparing your model for flight. If you have to carry the model to the take-off point with the engine running, be especially cautious. Keep the propeller pointed away from you and walk well clear of spectators.
- Warning! Immediately after a glowplug-ignition engine has been run and is still warm, conditions sometimes exist whereby it is just possible for the engine to abruptly restart if the propeller is casually flipped over compression WITHOUT the glowplug battery being reconnected. Remember this if you wish to avoid the risk of a painfully rapped knuckle!

## ENGINE CONSTRUCTION

With this engine, the piston will feel tight at the top of its stroke (TDC) when the engine is cold.

This is normal.

The cylinder bore is a little tapered.

The piston and cylinder are designed to achieve a perfect running clearance when they reach their running temperatures.

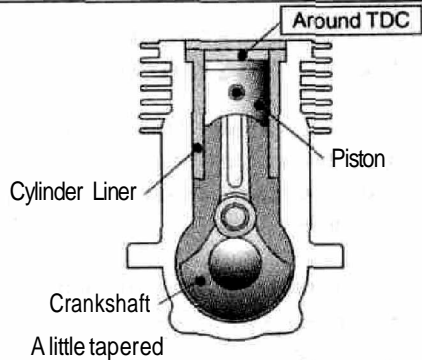

A little tapered

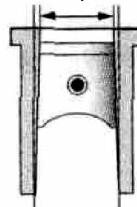

When the engine is cold.

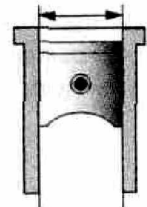

When the engine is hot

## NOTES WHEN APPLYING AN ELECTRIC STARTER

Do not over-prime. This could cause hydraulic lock and damage the engine on application of the electric starter.

If over-primed, remove glowplug, close needle-valve and apply starter to pump out surplus fuel. Cover the head with waste to prevent pumped out fuel coming into your eyes.

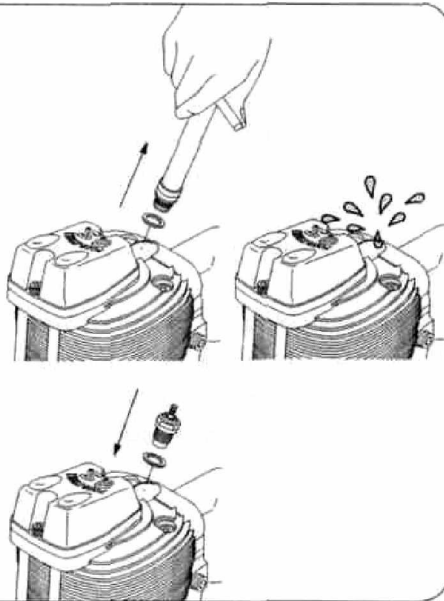

## INTRODUCTION

The FL-70 is an air-cooled, overhead-valve four stroke engine for model aircraft use. This engine is suitable for trainer, sport and scale models.

This engine reduces maintenance by incorporating the first O.S. ringless piston/liner assembly. Also, a sealed front bearing prevents oil leaks. The engine is fitted with the new easy-to use O.S. 60W airbleed carburetor. This engine is designed so that more R/O pilots, from hobby beginners to skilled Sunday fliers may enjoy the performance advantages of four stroke engines - greater fuel economy, higher torque, lower noise and realistic sound.

### STANDARD ACCESSORIES

- Glow Plug Type F  
(fitted with the engine)



- F-4030 Silencer Assembly

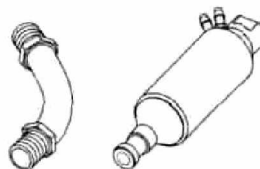

- T Nipple



## BEFORE STARTING

Tools, accessories, etc. The following items are necessary for operating the engine.

### ■ Items necessary for starting

#### GLOW PLUG

O.S. Type F glowplug is installed in the engine.



#### GLOWPLUG IGNITER

Commercially available handy glowplug heater in which the glowplug battery and battery leads are integrated.

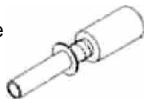

#### FUEL PUMP

Alternatively, one of the purpose-made manual or electric fuel pumps may be used to transfer fuel directly from your fuel container to the fuel tank.

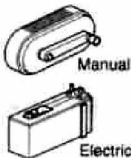

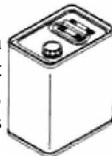

## FUEL

The FL-70 should be operated on a methanol based fuel containing not less than 20% (volumetric) castor oil, or a top quality synthetic lubricant (or a mixture of both), plus a small percentage (5-15%) of nitromethane for improved flexibility and power. (The carburetor is adjusted at the factory for a fuel containing 20% lubricant and 15% nitromethane.) Some commercial fuels also contain coloring additives as an aid to fuel level visibility. In some cases, these additives have indicated slightly negative effects on performance. We would suggest that you use such fuels only if you are satisfied that they do not adversely affect running qualities when compared with familiar standard fuels. When changing to a fuel brand or formula that is different from the one to which you are accustomed, it is a wise precaution to temporarily revert to in-flight running-in procedures, until you are sure that the engine is running entirely satisfactorily.



### Reminder!

 Model engine fuel is poisonous. Do not allow it to come into contact with the eyes or mouth. Always store it in a clearly marked container and out of the reach of children.

 Model engine fuel is also highly flammable. Keep it away from open flame, excessive heat, sources of sparks, or anything else which might ignite it. Do not smoke, or allow anyone else to smoke, near to it.

### Electric Starter and Starter Battery

Required when starting the engine.

12-Volt lead-acid battery

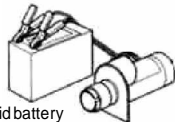

Electric Starter

### O.S. Super Filter (Fuel Can Filter)

Fit a filter to the outlet tube of your refueling container to prevent entry of foreign matter into fuel tank. O.S. 'Super Filters' (large and small) are available as optional extras.



### O.S. Non-Bubble Weight

To prevent the pickup from adhering to the tank wall under suction and restricting fuel flow, slots may be filed in the end of the weight. Alternatively, O.S. Non-Bubble Weight is available as an optional extra.



### Fuel Filter

It is recommended to fit a good in-line filter between the fuel tank and carburetor to prevent entry of foreign matter into the carburetor.



### Fuel Tank

A fuel tank of approximately 300cc capacity is suggested. This allows around 10 minutes flying time, dependent upon the type of fuel used, the size of propeller and on the proportion of full-throttle to part-throttle operation throughout the flight.

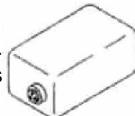

## Spinner

Since the FL-70 is intended to be started with an electric starter, the addition of a spinner assembly for centering the starter sleeve is desirable. Use a heavy-duty, well balanced spinner either of metal or plastic.



## SILICONE FUEL LINE

Heatproof silicone tubing of approx. 5mm o.d. and 2.5mm i.d. is required for the connection between the fuel tank and engine.



## Propellers

The choice of propeller depends on the design and weight of the aircraft and on the type of flying in which you will be engaged. Determine the best size and type after practical experimentation. As a starting point, refer to the props listed in the accompanying table. Slightly larger, or even slightly smaller, props

than those shown in the table may be used, but remember that the propeller noise will increase if blade tip is raised, due to higher rpm or if a larger-diameter/lower-pitched prop is used.

Sport & Aerobatic	12X7, 12.5X6, 13X6
Trainer & Scale	12.5X6, 13X6-7



## Warning:

Make sure that the propeller is well balanced. An unbalanced propeller and/or spinner can cause serious vibration which may weaken parts of the airframe or affect the safety of the radio-controlled system. DO NOT forget the WARNINGS and NOTES on propeller and spinner safety given on front pages.

## Reminder!

 Never touch, or allow any object to come into contact with, the rotating propeller and do not crouch over the engine when it is running.

- **TOOLS**

**HEX WRENCH**

Necessary for engine installation.

1.5mm, 2mm, 2.5mm, 3mm opposite side

**Plus Threaded Drivers**

No.1, No.2, etc.

**SCREWDRIVER**

Necessary for carburetor adjustments.

No.1, No.2, etc

**Box Wrenches**

5.5mm, 7mm, 8mm opposite side

**LONG SOCKET WRENCH WITH PLUG GRIP**

Recommended for easy removal and replacement of the angled and recessed glowplug, the O.S.Long Socket Wrench incorporates a special grip.

**Spanners**

8mm, 13mm, 14mm, etc.

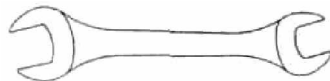
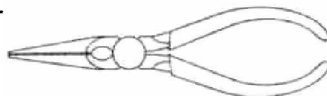
**Nipper**

## Engine Parts Name

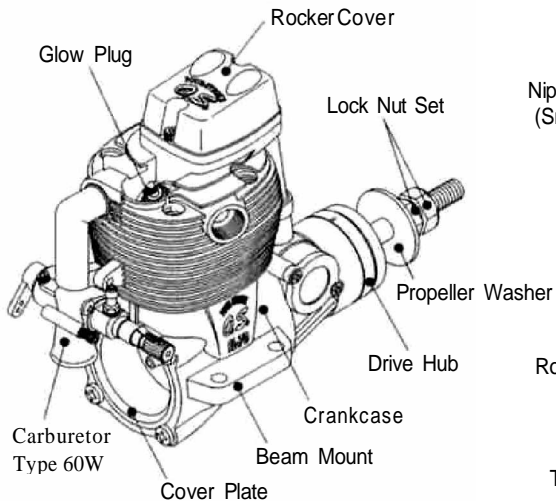

## F-4030 Silencer Assembly

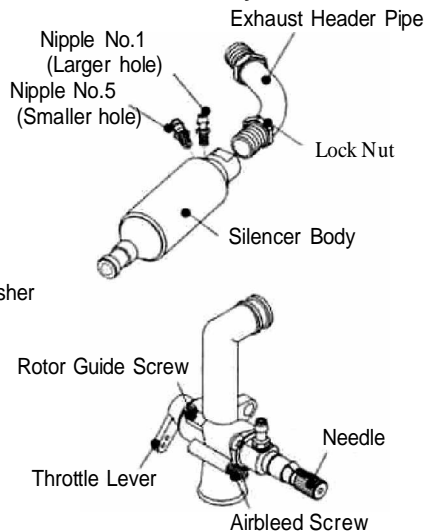

## INSTALLATION

Because the FL-70 is a powerful, large-displacement, single-cylinder four-stroke-cycle engine, it is essential to use very substantial engine mounting. Conventional wooden mounting beams should be of rigid hardwood and of at least 15mm or 5/8-in square section.

**Make sure that the mounting beams are parallel and that their top surfaces are in the same plane.**

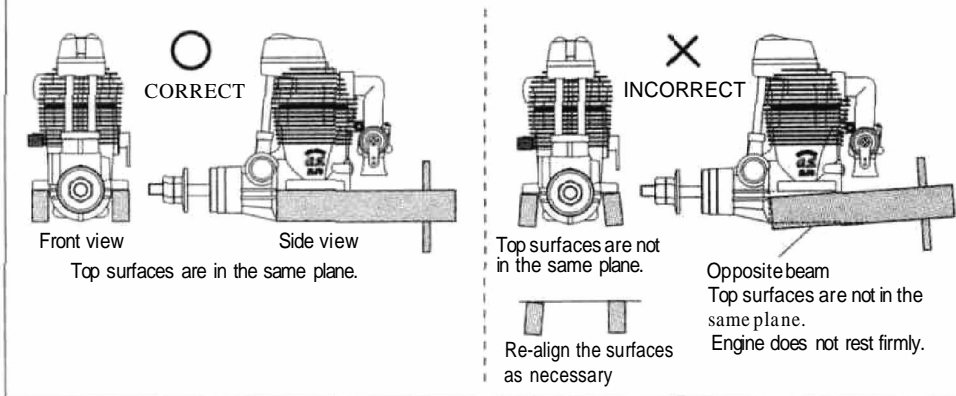

## How to fasten the mounting screws.

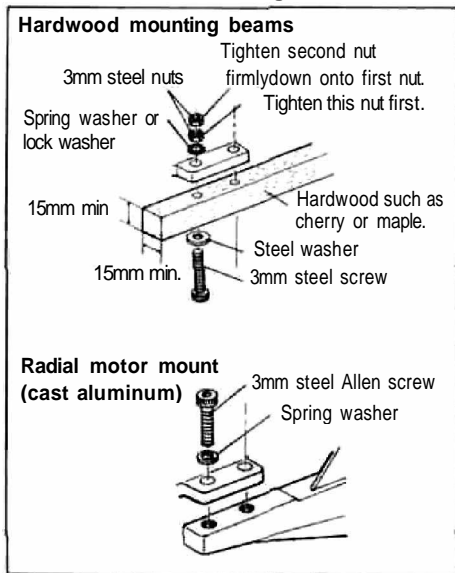

- Make sure that these mounting beams are accurately aligned and firmly integrated with the airframe, reinforcing the adjacent structure to absorb vibration. Use 3mm or larger steel screws, preferably Allen type hexagon socket head cap screws, with washers and locknuts, for bolting the engine to the bearers.

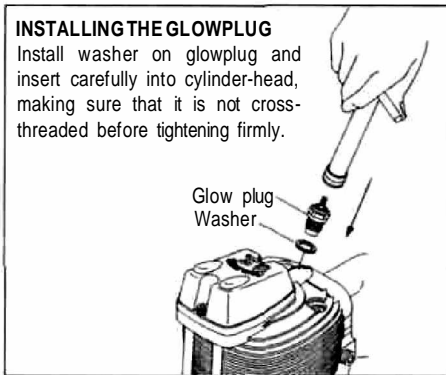

## SILENCER & EXHAUST HEADER PIPE INSTALLATION

**Screw the header pipe into the cylinder head** until it "bottoms" , then unscrew sufficiently to achieve the desired exhaust angle and tighten the lock nut securely with a 14mm wrench. Screw the silencer onto the outer end of the header pipe and tighten the other locknut.

The application of a heatproof silicone sealant to the threads of the exhaust system is recommended to reduce the risk of joints loosening and the leakage of exhaust gasses and oil residue.

### **Reminder:**

**Model engines generate considerable heat and contact with the header pipe or silencer may result in a serious burn.**

**If you need to tighten the silencer joints, which may loosen when they are hot, use a thick folded cloth for protection.**

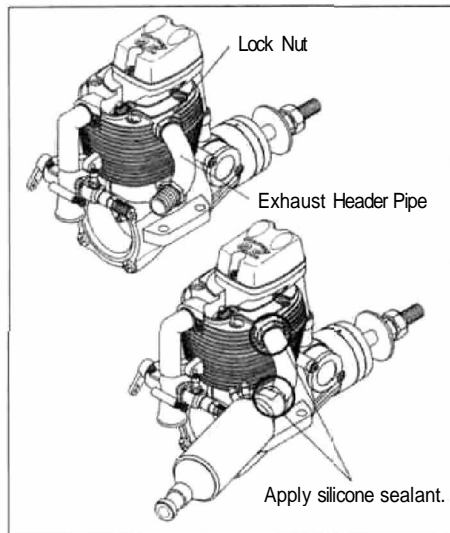

---

## FUEL TANK & LINES

- Make sure that the tank is well rinsed out with methanol or glow fuel before installation and that the pickup weight is well clear of the bottom of the tank when held vertically.
- Connect between pressure nipple on the silencer (larger hole one) and the tank to apply muffler pressurized fuel feed system which deliver the fuel stably reducing fuel level negative effect.
- Connect between breather nipple on the cover plate and silencer breather nipple (smaller hole one).

### General Piping

- Make connections as shown in the Fig.1.  
An airbleed type carburetor is required to set idling r.p.m. a little higher to prevent engine cutting.

### Piping suitable for acrobatic flights

- With the general piping, the fuel in the tank may flow into the silencer when the throttle is set to slow during upside-down flight or vertical dive, which may result in engine stop due to mixture change at low speed. Piping shown in the Fig 2 prevents fuel flowing into the silencer, and engine stop at slow running during maneuvers. Also, this piping allows to set the idling r.p.m. a little lower and longer flight by preventing excess fuel flowing out.
- When the tank is filled (when the fuel level is higher than the carburetor center line.), prevent the fuel flowing into the carburetor with a commercially available fuel stopper, etc. Release the stopper before starting the engine.

**Fig. 1 General Piping**

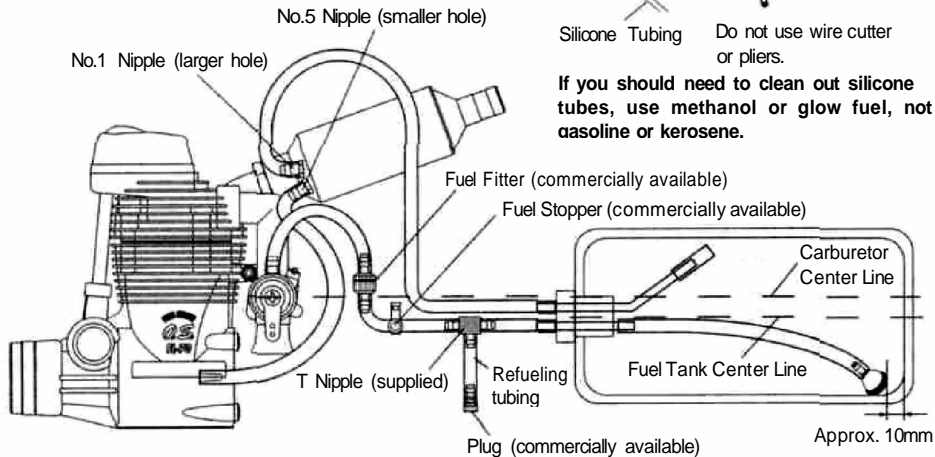

**Fig. 2 Piping suitable for acrobatic flights**

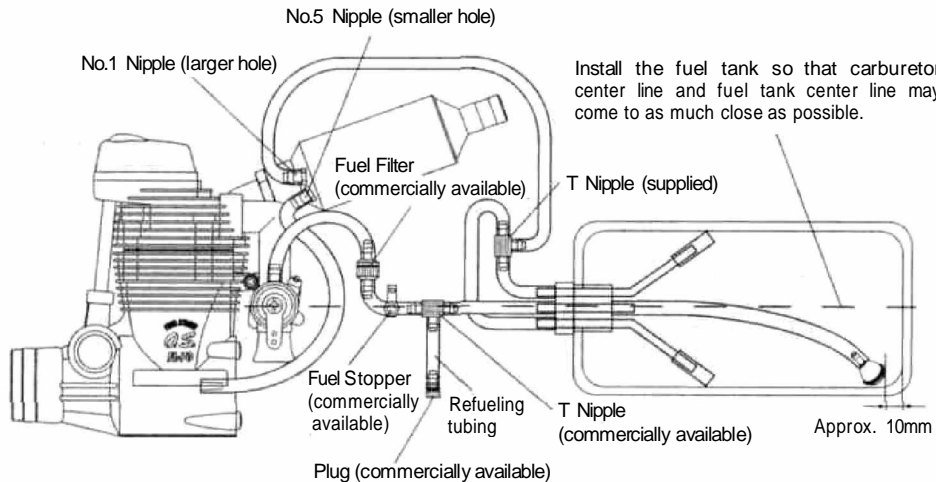

---

## THROTTLE LINKAGE

Before connecting the throttle to its servo, make sure that the throttle arm and linkage safely clear any adjacent part of the airframe structure, etc., as the throttle is opened and closed.

Connect the linkage so that the throttle is fully closed when the transmitter throttle stick and its trim lever are at their lowest settings and fully open when the throttle stick is in its fully-open position..

Carefully align the appropriate holes in the throttle arm and servo horn so that they move symmetrically and smoothly through their full travel.

---

## NEEDLE-VALVE EXTENSION

The needle-valve supplied with this engine is designed to incorporate an extension so that, when the engine is enclosed within the fuselage, the needle-valve may be adjusted from the outside. Cut a commercially available rod to the required length, bend one end to an L shape, insert it into needle's center hole and secure it by tightening the set-screw in the needle-valve knob with 1.5mm Allen key.

Needle Valve Extension Cable Set (Code No. 72200080) is available from O.S. as an optional part.

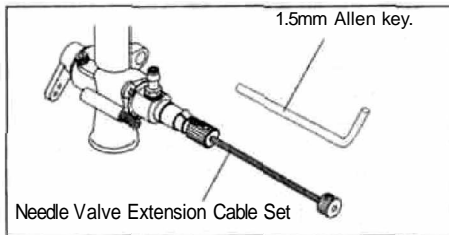

## PROPELLER & SPINNER ATTACHMENT

There is a risk, particularly with powerful four-stroke engines, of the propeller flying off if the prop nut loosens due to detonation ("knocking") in the combustion chamber when the engine is operated too lean, or under an excessively heavy load.

Obviously, this can be very hazardous. To eliminate such dangers, the O.S. Safety Locknut Assembly was devised.

1. Ream the propeller shaft hole to 6.4-6.5mm bore with an appropriate reamer, checking that the hole is exactly centered.
2. Install the prop to the engine shaft, followed by retaining washer and prop nut lightly. Turn the prop counter-clockwise slowly to locate the position where compression is felt. At this position, fit the prop horizontally and tighten firmly the prop nut with a 13mm wrench.

3. Add the specially tapered and slotted locknut and secure with a 10mm wrench while holding the prop nut with the 13mm wrench.

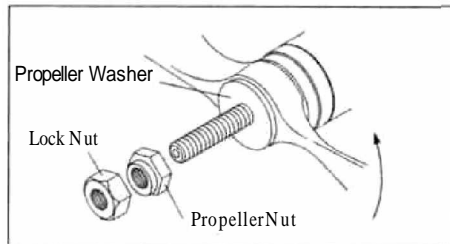

4. Fit a spinner assembly to start the engine with an electric starter.

Note:

Some spinners which are fixed at the top of the cone cannot be used with the prop locknut supplied with the engine. In this case, optional locknut sets are available from O.S. - Propeller Locknut Set for Spinner (Code No.45810200) and Propeller Locknut Set for Tru Turn Spinner (Code No.145810300).

IMPORTANT

Regardless of the type of propeller fixing used, make a habit of always checking the tightness of the propeller before starting the engine. Remember that, especially with wooden propellers, there is a tendency for the material to shrink, or for it to be reduced by the serrated face of the drive hub.

---

## GLOWPLUG

The FL-70 supplied with an O.S. Type F glowplug, specially designed for O.S. four-stroke engines.

### The role of the glowplug

With a glowplug engine, ignition is initiated by the application of a 1.5-volt power source. When the battery is disconnected, the heat retained within the combustion chamber remains sufficient to keep the plug filament glowing, thereby continuing to keep the engine running. Ignition timing is 'automatic' : under reduced load, allowing higher rpm, the plug becomes hotter and, appropriately, fires the fuel/air charge earlier; conversely, at reduced rpm, the plug become cooler and ignition is retarded.

### Glowplug life

Particularly in the case of very high performance engines, glowplugs must be regarded as expendable. However, plug life can be extended and engine performance maintained by careful use, i.e.:

- Install a plug suitable for the engine.
- Use fuel containing a moderate percentage of nitromethane unless more is essential for racing events.
- Do not run the engine too lean and do not leave the battery connected while adjusting the needle.

### When to replace the glowplug

Apart from when actually burned out, a plug may need to be replaced because it no longer delivers its best performance, such as when:

- Filament surface has roughened and turned white.
- Filament coil has become distorted.
- Foreign matter has adhered to filament or plug body has corroded.
- Engine tends to cut out when idling.
- Starting qualities deteriorate.

---

## TYPE 60W CARBURETTOR

Two adjustable controls are provided on this carburettor.

They are as follows:

- **The Needle Valve**

This is used to establish the fuel/air mixture strength required for full power when the throttle is fully open.

- **The Airbleed Screw**

This is used to establish the mixture strength required for steady idling and a smooth transition to medium speeds. (The varying mixture strength required between part-throttle and full-throttle running is automatically adjusted by coupled movement of the throttle.)

The sequence in which these controls are adjusted is explained in the succeeding sections, under Starting, Running-in and Idling Adjustment.

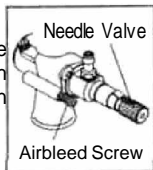

---

## STARTING

The FL-70 is not equipped with manual choke controls, as it is intended for use with an electric starter only.

A high-torque electric starter not only makes starting the engine easier, it dispenses with the need for a choke valve by turning the engine over fast enough to cause the fuel pump to prime the cylinder automatically.

**Starting procedure is as follows:**

1. Fill the fuel tank with fuel. When filled, prevent fuel flowing into the carburetor with a commercially available fuel stopper, etc. Release the stopper before starting the engine.
2. Make sure that plug element glows red, and fit the plug to the cylinder head.

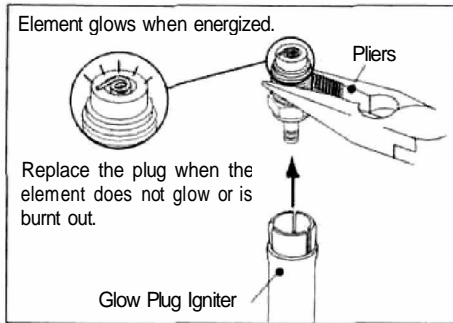

### WARNING

When checking the plug with energizing it, hold the plug with tools, such as pliers, etc. Do not bring your face close to the plug or the boiled fuel remaining in the filament will burn you.

3. Check that the current to the glowplug is switched off.

4. To close the needle-valve, turn it clockwise, while to open the needle-valve, turn it counter-clockwise. Turn the needle-valve clockwise slowly until it stops. This is the fully closed position.

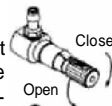

5. Open the needle-valve 2-2.5 turns from the fully closed position and set the throttle in the fully open position.



6. Apply the starter and press the starter switch for 5-6 seconds to prime the engine.

7. Position the throttle stick at 2-3 scales advanced from the fully pulled down position. Turn the prop "backwards" (clockwise) by hand until it is arrested by compression. This is to enable the kinetic energy of the prop to subsequently assist the starter through the compression stroke to start the engine.

8. Make sure that the rotating direction of the electric starter is correct. Energize the glowplug and apply the starter.
9. When the engine starts, slowly open the throttle to the mid speed position. Then, disconnect current to the glowplug. If at this point the engine stalls, it is probable that the mixture is excessively rich. Close the needle-valve a little and restart the engine.
10. Now close the needle-valve gradually so that revolutions are increased.

#### How to stop the engine

Pull down the throttle lever and trim lever on the transmitter fully.

#### Note:

Make sure that the throttle linkage is made so that the throttle is fully closed when the throttle lever as well as trim lever on the transmitter are fully pulled down.

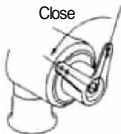

---

## RUNNING-IN ("Breaking-in")

For long life and peak performance, every engine needs special treatment when new, known as "running-in" or "breaking-in". This is a procedure during which the engine is operated under strictly controlled conditions at the beginning of its life, in order to avoid the risk of immediate damage to certain components through becoming overheated or stressed and to help working surfaces to become smoothed and aligned for maximum mechanical efficiency thereafter. With some engines, this can require a tediously protracted period of bench running, but, as O.S. engines are manufactured to fine tolerances and from the finest quality materials, a relatively brief running-in period is sufficient and can be completed with the engine installed in the aircraft. Prolonged running with too rich mixture and/or low speed will not complete the proper running-in.

On the contrary, prolonged low speed running may cause the oil in the fuel gelled, which may result in seizure of the piston and cylinder liner. The recommended procedure is as follows:

1. Use the same fuel and prop as you intend for flying your model.
2. Open the needle-valve 2.5 turns from the fully closed position and start the engine.
3. Open the throttle slowly to the mid speed position, and disconnect the current to the glowplug.
4. Now open the throttle slowly to the fully opened position and run the engine for no more than 5 seconds with the needle-valve tuned to produced near maximum r.p.m., then, immediately, slow the engine down again by opening the needle-valve approximately one turn. The rich mixture, so induced, will cool the engine, at the same time providing increased lubrication.
5. Repeat this process, alternately running the engine fast and slow by means of the needle-valve, while keeping the throttle fully open, then begin to extend the short periods of high-speed operation until two tanks of fuel have been consumed.

**WARNING:**

**When ground running the engine, avoid dusty or sandy locations. If dust or grit is drawn into the engine, this can be a ruinous effect, drastically shortening engine life ion a matter of minutes.**

6. Following the initial running-in session, check for any looseness in the installation due to vibration, then allow the engine a period of moderately rich operation in flight.
7. For the first flight, have the needle-valve set on the rich side and adjust the throttle trim on the transmitter so that the engine does not stop when the throttle is closed to the idle setting.

8. With each successive flight, close the needle-valve very slightly until, at the end of about 10 flights, the needle is set for full power. Do not "over-lean" the mixture in an attempt to extract more power.

**If overheating should be suspected at any time during flight (i.e. if the engine begins to "labor") reduce power by partially closing the throttle and land the aircraft to enable the needle-valve to be readjusted to a richer setting.**

---

## CARBURETOR

These engines are equipped with a throttle type carburetor which provides a wide range of engine speed control. With the throttle lever linked to a suitable servo in the model, movement of the throttle control on the transmitter will enable engine to be varied, proportionally, from idling speed to full power.

The carburetor of your engine has been factory set for the approximate best results and no adjustment (except to the needle-valve) should be required provided that the fuel tank is correctly located, as previously described. After the engine has been run-in, check the operation of the throttle according to the following chart. Re-adjust the controls only when necessary.

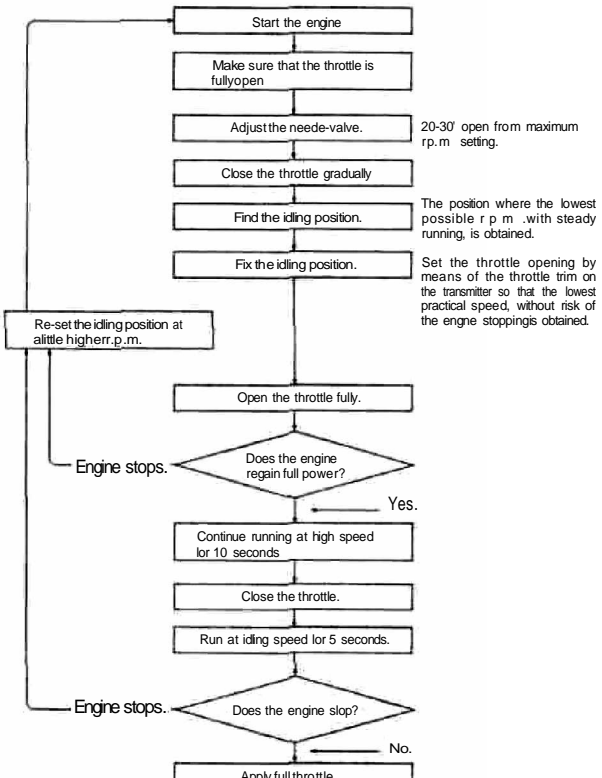

# CARBURETOR AIR-BLEED ADJUSTMENT

## Pre-Flight Check

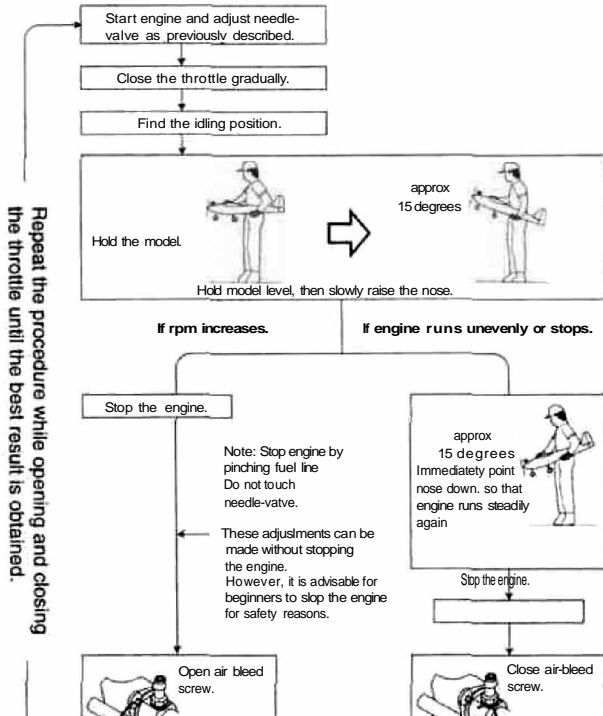

## TROUBLE SHOOTING WHEN THE ENGINE FAILS TO START

### Four key points

For quick, reliable starting, the following four conditions are required.

- (1.) Good compression. (2.) Adequate "glow" at glowplug. (3.) Correct mixture.  
 (4.) Sufficient electric starter rotating speed.

If the engine fails to start, or does not keep running after being started, check symptoms against the following chart and take necessary corrective action.

**Note:** The most common causes of trouble are marked with three asterisks, the less common problems with one or two asterisks.

Symptom	Factor	Cause	Corrective action	
Engine fails to fire.	①	* Sluggish rotation . . . . .	Recharge the electric starter battery.	
		②	*** Glowplug battery discharged, . . . . .	Recharge lead-acid cell or replace dry battery. (Note: An unused, or almost unused, dry battery may sometimes be of insufficient capacity if it is "old stock".)
			* Glowplug element is burned out . . . . .	Replace glowplug. Check that applied voltage is not too high.
			* Something wrong with battery leads . . . . .	Check glowplug heating using other leads
			*** Engine "flooded" due to excessive priming, . . . . .	Close needle-valve fully and remove glowplug, then flip propeller to pump out excess fuel. (Invert engine, if possible, while pumping out excess). Re-start engine. (Priming is not necessary at this time.)
③	* Insufficient priming. . . . .	Repeat priming procedure referring to Priming.		

Symptom	Factor	Cause	Corrective action
Engine fires Intermittently but does not run.	② — ★★	Incorrect heating of glowplug. . . . .	Voltage too high or too low. Re-check and readjust referring to "BEFORE STARTING".
	③ — ★★	Over priming. . . . .	Continue applying an electric starter. If the engine does not start after more than 4 tries, disconnect the current to the glowplug and leave for a few minutes, then re-energize plug and apply starter. If the engine still does not start, remove glowplug and pump out excess fuel by applying the <b>starter</b> .
	① — ★	Sluggish rotation. . . . .	Then re-start. (Priming is not necessary.) Recharge the electric starter battery.
Engine fires once or twice, then tails to fire.	② — ★★	Glowplug battery discharged. . . . .	Recharge lead-add cell or replace dry battery. (Note: An unused, or almost unused, dry battery may sometimes be of insufficient capacity if it is "old stock".)
Engine starts but rpm decreases and engine eventually stops.	③ — ★★	Insufficient priming. . . . .	Repeat priming procedure referring to Priming.
Engine starts. rpm increases and engine cuts out.	-③ — ★★★	Mixture too rich. . . . .	Close needle valve half turn (180°) and wait for several minutes then re-start (Priming is not necessary.)
Engine stops when the current to the glowplug is disconnected after starting	-③ — ★	Fuel not reaching the engine, . . . . .	Make sure that tank is filled with fuel. Check that there is not something wrong with the fuel line (kinked or split). Check that carburettor is not clogged with dirt.
	③ — ★★	Mixture too rich. . . . .	Close the needle-valve a little before disconnecting current to the glowplug.
	② — ★	Mismatch of glow plug and- . . . . .	Change fuel or glowplug.

---

## VALVE ADJUSTING

Valve clearances are correctly set before any O.S. engine leaves the factory and, in normal use, will seldom require adjustment. However, if, after a very considerable amount of running time has been consumed, a loss of power is detected, or if the engine has been disassembled for repair, these clearances should be checked and reset as necessary.

For checking and adjusting the valve clearances, VALVE ADJUSTING TOOL KIT is available as an optional accessory.

**The kit comes in a plastic case and includes:**

**(Code No.7220060)**

- Feeler gauge 0.04mm
- Feeler gauge 0.1 mm
- Hex. key 1.5mm
- Wrench 5mm

## HOW TO SET THE CAMSHAFT TIMING

When replacing the camshaft, set the timing as follows.

1. Secure propeller.

### NOTE:

**If propeller is not secured, crankshaft may move backward and correct timing cannot be set.**

2. Turn the crankshaft so that T mark on the drive hub may match crankcase center line. (This is engine T.D.C. position)
3. Push the camshaft into camshaft housing until it stops. Locate '•' mark on the side of camshaft gear in line with the push rod.
4. Rotate crankshaft right and left a little and make sure that the '•' mark on the gear is in line with the push rod when the 'T' mark on the drive hub matches the crankcase center line.
5. Secure cam cover with screws.

The relation of position between '•' mark of the gear and teeth may differ from the sketch, by each model.

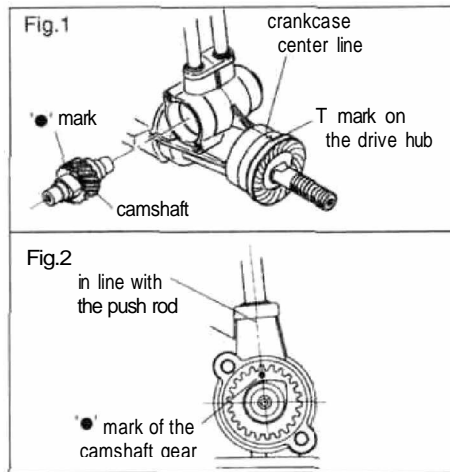

---

## CARE AND MAINTENANCE

**Please pay attention to the matters described below to ensure that your engine serves you well in regard to performance, reliability and long life.**

- As previously mentioned, it is vitally important to avoid operating the engine in conditions where dust, disturbed by the propeller, may be deposited on the engine and enter its working parts.
- Remember to keep your fuel container closed to prevent foreign matter from contaminating the fuel.
- Fit a fuel can filter to prevent dirt and dust in the fuel container entering the fuel tank. O.S. Super Filters (L) and (S) are available as optional extra.
- Fit an in-line fuel filter between the tank and carburetor to prevent dirt and dust in the tank entering the carburetor.
- Clean these filters periodically.
- If these precautions are neglected, restriction of fuel flow may cause the engine to cut out, or the fuel/air mixture to become too lean causing the engine to overheat.
- The use of modern high-performance alcohol based model engine fuels, while promoting cooler running, improved anti-detonation combustion and increased power, has the disadvantage of causing bottom end corrosion in a four-stroke engine. This is due to the acidic by products of combustion that accumulates in the engine's crankcase and are not flushed out by fresh air/fuel mixture as in the case of a two-stroke engine.

The use of nitromethane in the fuel can also contribute to the problem. As a primary defense, users are advised to avoid running the engine on too lean a mixture - i.e. do not close the needle-valve and the airbleed screw too much.

- Do not leave unused fuel in the engine at the conclusion of a day's flying. Accepted practice is to cut off the fuel supply while the engine is still running at full throttle, then expel as much fuel residue as possible by turning the engine over 5-10 seconds with the electric starter. Finally, inject some after-run oil through the glowplug hole and turn the engine over several times by hand.

- When the engine is not to be used for some months (for example, as between flying seasons), a worthwhile precaution is to remove it from the airframe and, after washing off the exterior with alcohol (not gasoline nor kerosene), remove carefully the carburetor with intake pipe, glow plug and all silicone tubing and put them safely aside. Then, immerse the engine in a container of alcohol. Rotate the crankshaft while the engine is immersed. If foreign matter is visible in the alcohol, rinse the engine again in clean alcohol. Finally, shake off and dry the alcohol, and inject some after-run oil from glowplug hole and rotate the crankshaft several times by hand. Re-fit the carburetor with intake pipe and glowplug with the engine and keep it dry place after putting in a vinyl bag.

# ENGINE EXPLODED VIEW

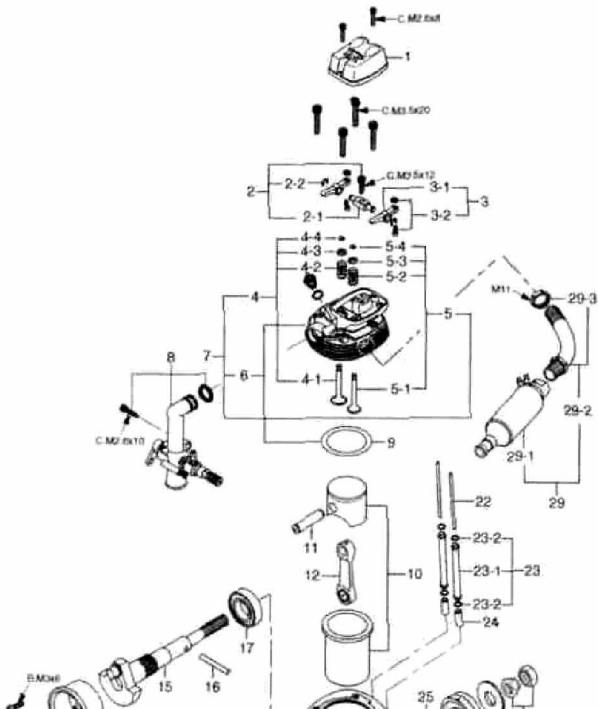

No.	Code No	Description
1	44404200	Rocker Cover
2	45961400	Rocker Support Assembly
2-1	45961410	Rocker Support
2-2	45761600	Rocker Arm Retainer (2pcs.)
3	44753000	Rocker Arm Assembly (1pair)
3-1	44753100	Rocker Arm (1pc.)
3-2	45761200	Tappet Adjusting Screw
4	44460000	Intake Valve Assembly (1 pair)
4-1	44460100	Intake Valve (1pc.)
4-2	45960210	Valve Spring (1pc.)
4-3	45060309	Valve Spring Seal (1pc.)
4-4	46160400	Valve Spring Retainer (2ps.)
5	44461000	Exhaust Valve Assembly (1pair)
5-1	44461100	Exhaust Valve(1pc.)
5-2	45960210	Valve Spring (1pc.)
5-3	45060309	Valve Spring Seat (1pc.)
5-4	46160400	Valve Spring Retainer (2ps.)
6	44404100	Cylinder Head(W/Gasket)
7	44404000	Cylinder Head (W/Gasket and Valve Assembly)
8	44481000	Carburetor Complete (60W)
9	44714100	Head Gasket
10	44403000	Cylinder & Piston Assembly
11	45906000	Piston Pin
12	44405000	Connecting Rod
13	44407009	Cover Plate Retaining Screw
14	44407000	Cover Plate
15	44402000	Crankshaft
16	44408100	Drive Pin
17	44430000	Crankshaft Ball Bearing (Rear)
18	44401000	Crankcase
19	44462000	Camshaft
20	44401100	Cam Cover
21	44701109	Cam Cover Retaining Screw
22	44766000	Push Rod (2pcs.)
23	44766100	Push Rod Cover Assembly (2pcs.)
23-1	44766110	Push Rod Cover (1pc.)
23-2	24881824	Push Rod Cover "O" Ring (2pcs.)
24	45664000	Cam Follower (2pcs.)
25	44731000	Crankshaft Ball Bearing (Front)
26	44408000	Drive Hub
27	23209003	Propeller Washer

## CARBURETOR EXPLODED VIEW

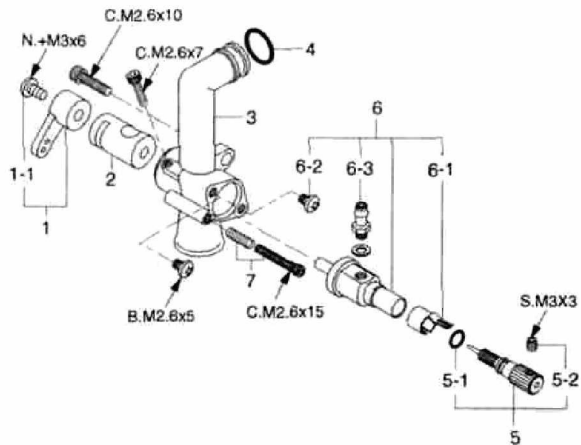

\*Type of screw

C Cap Screw B Binding Head Screw M Oval Fillister-Head Screw  
F...Flat Head Screw N Round Head Screw S .Set Screw

---

## CARBURETTOR PARTS LIST

No.	Code No.	Description
1	22081408	Throttle Lever Assembly
1-1	22081313	Throttle Lever Retaining Screw
2	44481200	Carburetor Rotor
3	44481100	Carburetor Body
4	45915000	Carburetor Rubber Gasket
5	22681980	Needle-valve Assembly
5-1	24981837	"O" Ring (2pcs.)
5-2	26381501	Set Screw
6	44481960	Nozzle Assembly
6-1	26711305	Ratchet Spring
6-2	45281920	Nozzle Retaining Screw (2pcs.)
6-3	22681953	Fuel Inlet (No.1)
7	44481310	Air-bleed Screw

Specifications are subject to alteration for improvement without notice.

## O.S. GENUINE PARTS & ACCESSORIES

- **O.S.GLOW PLUG**  
TYPEF  
(71615009)



- **BOOSTER CABLE SET**  
(72200110)



- **BOOSTER**  
**TERMINAL KIT**  
(72200130)



- **PROPELLER**  
**LOCKNUT SET**  
(45810100)  
  
(45810200 For Spinner)



- **Needle Valve Extension**  
**Cable Set**  
(72200080)



- **PROPELLER LOCKNUT SET**  
**FOR TRU-TURN SPINNER**  
1/4"-M5 (45810300)



- **FLEXIBLE EXHAUST PIPES**



- **EXHAUST HEADER PIPES**  
(72109500) (72109600)



Inside



Outside

Code.No.	Type	Length (mm)
72108100	1111A	120
72108110	HUB	240
72108120	1111C	170
72108130	1111D	330

---

■ **NON-BUBBLE WEIGHT**

(71531000)



■ **LONG SOCKET WRENCH WITH PLUG GRIP**

(71521000)

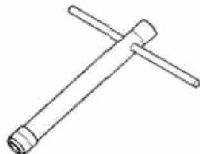

■ **VALVE ADJUSTING TOOL KIT**

(72200060)

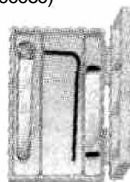

■ **SUPER FILTER (L)**

(72403050)



---

■ **LOCK WASHER**

(10sets)

M3 (55500002)



■ **BLIND NUT (10pcs./sets)**

M3 (79870030)



■ **CAP SCREW SETS (10pcs./sets)**

M2.6x8 (79871025)

M2.6x10(79871030)

M3.5x12(79871080)

M3.5x20(79871100)



The specifications are subject to alteration (or improvement without notice).

### THREE VIEW DRAWING Dimension(mm) Specification

■ Displacement	11.45cc(0.698cu.in.)
■ Bore	27.7mm (1.090 in.)
■ Stroke	19.0mm (0.748 in.)
■ Practical R.P.M.	2.300-12.000 r.p.m.
■ Power output	1.1ps/ 11.000 r.p.m.
■ Weight	467g (16.480Z.)
(Silencer including exhaust header pipe)	51.5g(1.8oz.)

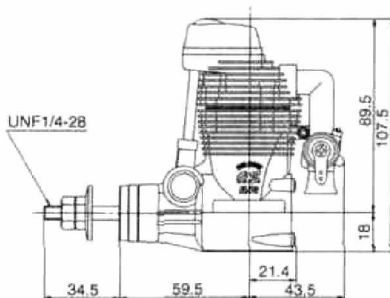
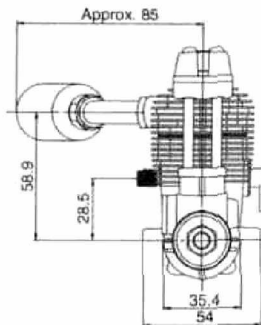
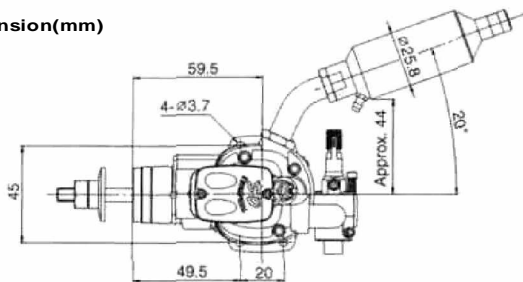

44



***O.S. ENGINES*** MFG.CO.,LTD.

6-15 3-Chome Imagawa Higashisumiyoshi-ku  
Osaka 546-0003. Japan TEL. (06) 6702-0225

FAX. (06) 6704-2722

URL: <http://www.os-engines.co.jp>

(C) Copyright 2004 by O.S.Engines Mfg. Co.. Ltd. All rights reserved. Printed in Japan.

60091500

[www.modelflight.com.au](http://www.modelflight.com.au)