

---

---

**O.S. ENGINE**

**MAX-50SX-HRING**

---

---

## OWNER'S INSTRUCTION MANUAL

It is of vital importance, before attempting to operate your engine, to read the general **'SAFETY INSTRUCTIONS AND WARNINGS'** section on pages 2-5 of this booklet and to strictly adhere to the advice contained therein.

Also, please study the entire contents of this instruction manual, so as to familiarize yourself with the controls and other features of the engine.

Keep these instructions in a safe place so that you may readily refer to them whenever necessary.

It is suggested that any instructions supplied with the model, radio control equipment, etc., are accessible for checking at the same time.

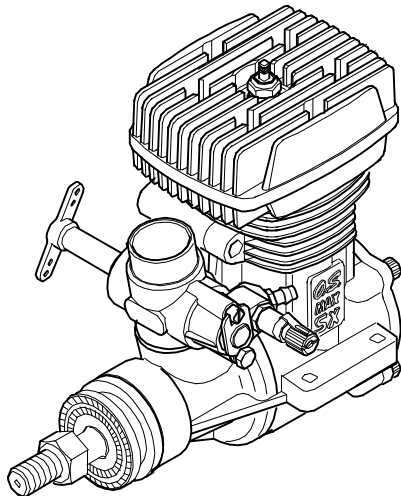

[www.modelflight.com.au](http://www.modelflight.com.au)

## CONTENTS

SAFETY INSTRUCTIONS AND WARNINGS ABOUT YOUR O.S. ENGINE -----	2~5	SUBSEQUENT READJUSTMENTS -----	18
INTRODUCTION -----	6	CARBURETTOR CLEANLINESS ADJUSTING CHART -----	19
BASIC ENGINE PARTS, INSTALLATION -----	7~8	INSTALLATION OF THROTTLE SERVO -----	20
BEFORE STARTING -----	8~10	CARE AND MAINTENANCE -----	21
FACTS ABOUT GLOW PLUGS FUEL -----	10~11	ENGINE EXPLODED VIEW & PARTS LIST -----	22~23
CARBURETOR CONTROLS -----	12~13	CARBURETOR EXPLODED VIEW & PARTS LIST -----	24
STARTING -----	13~14	THREE VIEW DRAWING -----	25
RUNNING-IN,ADJUSTMENT -----	15~18	O.S. GENUINE PARTS & ACCESSORIES -----	26

## **SAFETY INSTRUCTIONS AND WARNINGS ABOUT YOUR O.S. ENGINE**

Remember that your engine is not a "toy", but a highly efficient internal-combustion machine whose power is capable of harming you, or others, if it is misused.

As owner, you, alone, are responsible for the safe operation of your engine, so act with discretion and care at all times.

If at some future date, your O.S. engine is acquired by another person, we would respectfully request that these instructions are also passed on to its new owner.

■ The advice which follows is grouped under two headings according to the degree of damage or danger which might arise through misuse or neglect.



### **WARNINGS**

These cover events which might involve serious (in extreme circumstances, even fatal) injury.



### **NOTES**

These cover the many other possibilities, generally less obvious sources of danger, but which, under certain circumstances, may also cause damage or injury.



## WARNINGS

- Never touch, or allow any object to come into contact with, the rotating parts.



- Model engine fuel is poisonous. Do not allow it to come into contact with the eyes or mouth. Always store it in a clearly marked container and out of the reach of children.



- Model engine fuel is also highly flammable. Keep it away from open flame, excessive heat, sources of sparks, or anything else which might ignite it. Do not smoke or allow anyone else to smoke, near to it.



- Never operate your engine in an enclosed space. Model engines, like automobile engines, exhaust deadly carbon-monoxide. Run your engine only in an open area.

- Model engines generate considerable heat. Do not touch any part of your engine until it has cooled. Contact with the muffler (silencer), cylinder head or exhaust header pipe, in particular, may result in a serious burn.





## NOTES

- These engine were designed for model helicopters. Do not attempt to use it for any other purpose.
- Mount the engine in your model securely, following the manufacturers' recommendations, using appropriate screws and locknuts.
- Install an effective silencer (muffler). Frequent close exposure to a noisy exhaust (especially in the case of the more powerful high-speed engines) may eventually impair your hearing and such noise is also likely to cause annoyance to others over a wide area.
- Check the linkage to the throttle arm before each flight.
- Avoid sudden high r.p.m. immediately after the engine is started, as the clutch will engage and
- After starting the engine, carry out any needle-valve readjustments after stopping the rotor by closing the throttle to the lowest r.p.m.. Stop the engine before attempting to make other adjustments to the carburetor.
- Use an electric starter. The wearing of safety glasses is also strongly recommended. Press the rotor head down securely.
- Take care that the glow plug clip or battery leads do not come into contact with rotating parts.
- Adjust the throttle linkage so that the engine stops when the throttle stick and trim lever on the transmitter are fully retarded. Alternatively, the engine may be stopped by cutting off the fuel supply. Never try to stop the engine



## NOTES

- Take care that loose clothing (ties, shirt sleeves, scarves etc.) do not come into contact with the rotor. Do not carry loose objects (such as pencils, screwdrivers, etc.) in a shirt pocket from where they could fall through the rotor disc.
- For their safety, keep all onlookers (especially small children) well back (at least 20 feet or 6 metres) when preparing your model for flight. If you have to carry the model to the take-off point with the engine running, be especially cautious. Hold the rotor securely and keep well clear of spectators.
- Warning! Immediately after a glowplug-ignition engine has been run and is still warm, conditions sometimes exist whereby it is just possible for the engine to restart when turned over WITHOUT the glowplug battery being reconnected. Remember this if you wish to avoid the risk of accidents.

---

## **INTRODUCTION**

**This is a high performance engine developed expressly for F3C M class helicopter competition utilizing 50 cubic inch engines.**

**The engine uses the same mounting hole spacing as the O.S. 46FX-H RING making the two engines interchangeable.**

**A special machined drive washer and dual throttle levers are supplied as standard for helicopter use.**

### **Note:**

**Because of initial tightness, a standard electric starter may have difficulty in rotating the engine when cold, before it has been adequately run-in. In this case, use a high-torque type starter.**

**DO NOT, however, confuse tightness with the symptoms of hydraulic lock caused by an excess of fuel within the cylinder - often the result of over-priming.**

**Attempting to force the engine to turn over in this condition may cause internal damage. Instead, remove the glowplug, invert the engine and eject surplus fuel from the combustion-chamber.**

---

## BASIC ENGINE PARTS

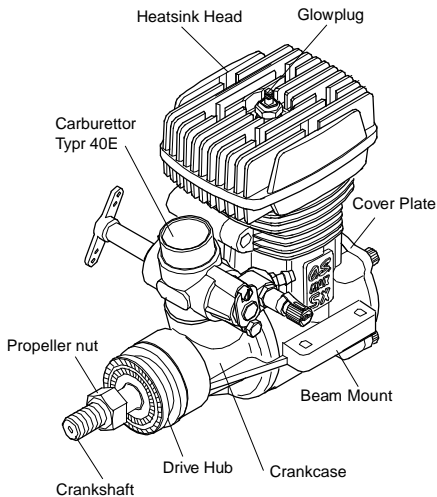

---

## INSTALLING THE GLOWPLUG

Install the washer on the glowplug and screw carefully into cylinder-head, making sure that it is not cross-threaded before tightening firmly.

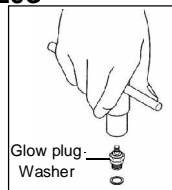

---

## INSTALLATION OF THE ENGINE

The under-surfaces of all O.S. engine beam mounting lugs are precision machined flat and exactly parallel to the engine's horizontal axis. It is essential that the engine mounts in the model are also accurately made and aligned. If they are not, they will cause stress and distortion within the engine itself, probably resulting in loss of performance and internal damage.

The recommended screws for securing the engine to the engine mounts in the model are 3mm or 4-40 steel Allen type. It is also advisable to use lock washers or LOCTITE to prevent nuts from loosening.

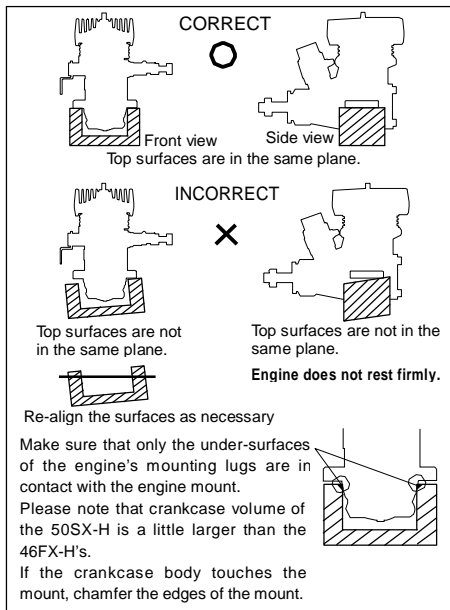

## INSTALLATION OF THE CARBURETOR

As delivered, the engine has its carburetor lightly fitted into its intake boss. Secure it as follows.

1. Loosen the retainer screw, rotate the carburetor to its correct position and press it well down into the intake boss, compressing the rubber gasket as shown in the sketch, before re-tightening screw.
2. Rotate the retainer screw gently until it stops, then tighten a further 90-120 degrees. Do not over-tighten the screw as this will damage the thermo-insulator.

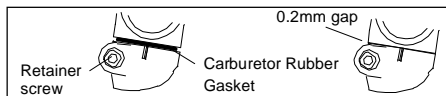

## BEFORE STARTING

### Tools, accessories, etc.

The following items are necessary for operating the engine.

#### 1 Fuel

Model glowplug engine fuel of good quality, preferably containing a small percentage of nitromethane.

## 2 Glowplug

O.S. No.8 glowplug is installed in the engine.

## 3 Glowplug battery

The power source for heating the glowplug may be either a large heavy-duty 1.5volt dry cell, or preferably, a 2-volt rechargeable lead-acid cell .

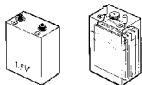

1.5 volt heavy-duty dry battery or 2 volt rechargeable lead-acid cell (at least 5Ah)

If a 2-volt cell is employed, use a resistance wire, as shown, to reduce applied voltage, otherwise element will overheat and burn out.

### Warning (Very hot)

Never touch the nichrome wire while the battery is connected.

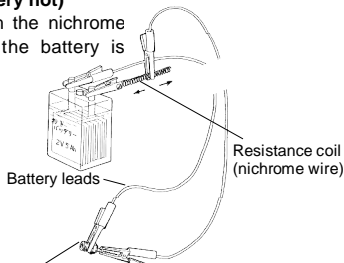

Adjust applied voltage by changing the position of clip on resistance coil until glowplug element is glowing bright red.

## 4 Plug wrench

Used for tightening glowplug. The O.S. long plug wrench is available as an optional accessory.



For tightening glowplug

## 5 Battery leads

These are used to conduct current from the battery to the glowplug. Basically, two leads, with clips, are required, but, for greater convenience, twin leads with special glowplug connectors, as shown on the right, are commercially available.



Battery leads

## 6 Fuel bottle or pump

For filling the fuel tank, a simple, polyethylene "squeeze" bottle, with a suitable spout, is all that is required. Alternatively, one of the purpose-made manual or electric fuel pumps may be used to transfer fuel directly from your fuel container to the fuel tank.



Fuel bulb

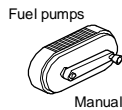

Fuel pumps

Manual

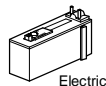

Electric

### 7 Fuel container filter

Install a filter on the outlet tube of your refuelling container to prevent entry of foreign matter into the fuel tank

Fuel Can Filter



### 8 Silicone tubing

This is required for the connection between the fuel tank and engine.

Silicone tube

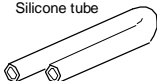

### 9 Hexagon starting shaft

This shaft mounted on an electric starting motor is driven into the main body of a helicopter to turn the engine.



### 10 Electric starter and starter battery

An electric starter is recommended for starting.

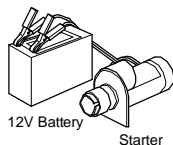

---

## FACTS ABOUT GLOWPLUGS

Since the compatibility of glowplug and fuel may have a marked effect on performance and reliability, it may be worthwhile to choose the R/C type plug found most suitable after tests. Recommended O.S. plugs are No.8, A5 and A3. Carefully install plug finger-tight, before final tightening with the correct size plug wrench.

### The role of the glowplug

With a glowplug engine, ignition is initiated by the application of a 1.5-volt power source. When the battery is disconnected, the heat retained within the combustion chamber remains sufficient to keep the plug filament glowing, thereby continuing to keep the engine running. Ignition timing is 'automatic' : under reduced load, allowing higher rpm, the plug becomes hotter and, appropriately, fires the fuel/air charge earlier; conversely, at reduced rpm, the plug become cooler and ignition is retarded.

### Glowplug life

Particularly in the case of very high performance engines, glowplugs must be regarded as expendable

However, plug life can be extended and engine performance maintained by careful use, i.e.:

- Install a plug suitable for the engine.
- Use fuel containing a moderate percentage of nitromethane.
- Do not run the engine too lean and do not leave the battery connected while adjusting the needle.

### When to replace the glowplug

Apart from when actually burned out, a plug may need to be replaced because it no longer delivers its best performance, such as when:

- Filament surface has roughened and turned white.
- Filament coil has become distorted.
- Foreign matter has adhered to filament or plug body has corroded.
- Engine tends to cut out when idling.

---

## FUEL

Select, by practical tests, the most suitable fuel from among the best quality fuels available in your country for helicopter use. For the best throttle response, a fuel containing 10% to 30% nitromethane is preferable. Lubricants may be either castor-oil or a suitable synthetic oil (or a blend of both) provided that they are always of top quality. For consistent performance and long engine life, it is essential to use fuel containing AT LEAST 18% lubricant by volume. Some fuels containing coloring additives tend to deteriorate and may adversely affect running qualities. If in doubt compare to a fuel known to be good.

### Reminder!



**Model engine fuel is poisonous. Do not allow it to come into contact with the eyes or mouth. Always store it in a clearly marked container and out of the reach of children. Model engine fuel is also highly flammable. Keep it away from open flame, excessive heat, sources of sparks, or anything else which might ignite it. Do not smoke, or allow anyone else to smoke, near to it.**



## CARBURETOR CONTROLS

With a fixed-wing model, power failure is rarely a serious threat to the safety of the aircraft since it can usually glide down to a safe landing. In a helicopter, on the other hand, it is vitally important that the engine keeps running and that there is a quick and reliable response to the throttle in order to ensure safe ascent and descent of the model.

**Two adjustable controls are provided on this carburetor.**

- **The Needle Valve:**

When set to produce maximum power at full throttle, this establishes the basic fuel/air mixture strength. This is then maintained by the carburetor's automatic mixture control system to cover the engine's requirements at reduced throttle settings.

- **The Mixture Control Valve (Mixture Control Screw):**

For adjusting the mixture strength at part-throttle and idling speeds, to obtain steady idling and smooth acceleration to medium speeds. The Mixture Control Valve has been factory set for the approximate best result. First, run the engine as received, and re-adjust the Mixture Control Valve only when necessary.

## BASIC POSITION OF MIXTURE CONTROL VALVE (Mixture Control Screw)

As delivered, the Mixture Control Screw is positioned at the center as shown in the sketch.

Mixture gets lean when the Mixture Control Screw is turned right, while mixture gets rich when the Mixture Control Screw is turned left.

With a model helicopter, adjustments vary with combined various factors such as climatic conditions, fuel, muffler, main rotor, weight of the model, gear ratio, etc. Therefore, Mixture Control Screw position varies with each model and set-up, and it is normal if the Mixture Control Screw position is off center.

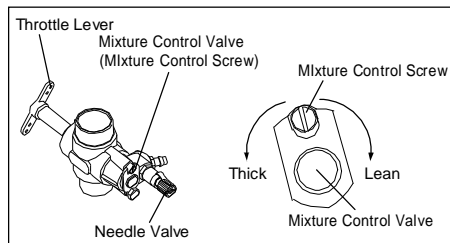

## Graduations on the carburetor body

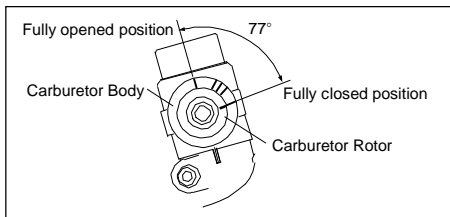

As shown in the sketch, the carburetor has graduation marks. When the triangle mark on the carburetor rotor meets the far right mark, the throttle is fully closed. When the triangle mark meets the top mark, the throttle is fully open. The range is 77 degrees. You may use the other three marks as the reference marking of throttle opening to your preference when hovering.

### **WARNING!**

**Never try to check the triangle mark position while the engine is running and rotor is rotating, or you may be hit by rotating rotor which results in serious injury. Stop the engine and rotor before checking the triangle mark position.**

## STARTING

Be sure to use a muffler pressurized fuel feed. Use the same fuel as you intend to employ for actual operation of your model.

### 1. Opening and closing of the Needle-Valve

Turn the needle clockwise to close the needle-valve, and turn the needle counter-clockwise to open the needle-valve as shown in the sketch.

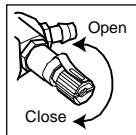

### 2. Opening the needle-valve

Firstly, turn the needle clockwise slowly until it stops. The position it stops is the fully closed position of the needle-valve. Make note this position for reference..

Open the needle-valve 2 turns.

### 3. Preparation of the starter

Install the starting shaft to the starter securely. Poor installation swings the starting shaft, which is dangerous.

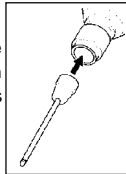

#### 4. Checking the rotating direction of the starter

Make sure that the starter rotates to the direction shown in the sketch. If the direction is reverse, reverse the leads on battery.

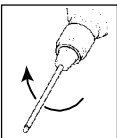

#### 5. Inserting the starter shaft

Insert the starting shaft into the shaft cup securely.

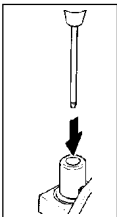

#### 6. Priming

Without heating the glowplug, open the throttle a little from the idling position. Turn the engine using the starter until the fuel is seen to reach carburetor.

#### 7. Preparation of starting

Make sure that the transmitter throttle stick is at the fully closed position and the throttle trim at center position, and make sure that idle-up switch on the transmitter is off. Hold the rotor head by hand so that rotor cannot rotate when the engine is Started. Also, steady the model with a foot on the landing-gear skid.



#### 8. Starting

Connect the battery to the glowplug and start the engine by applying the starter. When started, switch off the starter and withdraw the starting shaft after making sure the rotation of the starter shaft stops.

#### 9. Stopping the engine

Fully pull down the throttle trim on the transmitter.

#### In case the engine does not stop.

Hold the rotor head, and pinch the silicone tube to stop the fuel supply. If it still does not stop, pull off the fuel tubing from the carburetor.

It is necessary to readjust the throttle linkage so that the carburetor rotor is fully closed when the throttle stick and throttle trim on the transmitter are fully pulled Down.

**NOTE:**

If the throttle response is poor or the engine stops due to a temporarily over-rich mixture immediately after the engine is started, pinch the fuel line for one or two seconds until the engine r.p.m. increase and the engine runs steadily.

**Reminder!**

Never touch, or allow any object to come into contact with, the rotating rotor.



---

## **RUNNING-IN ("Breaking-in")**

All internal-combustion engines benefit, to some degree, from extra care when they are run for the first few times—known as running-in or breaking-in.

This allows the working parts to mate together under load at operating temperature.

However, because O.S. engines are made with the aid of the finest modern precision machinery and from the best and most suitable materials, only a very

short and simple running-in procedure is required and can be carried out with the engine installed in the model. For the first few flights with a new engine—i.e. while the engine is being run-in—set the needle-valve for a slightly rich mixture—not excessively rich as this may result in poor throttle response and cause the engine to stop. About 2 turn open from the normal setting will usually suffice.

---

## **ADJUSTMENT**

The following adjustments are approximately correct when using a fuel containing 25% lubricant and 10-30% nitromethane.

Bear in mind that fuels containing relatively large percentages of power-boosting nitromethane operate at richer mixture settings than are needed for mild fuels and will, therefore, require the Needle Valve to be readjusted accordingly. The type and percentage of lubricant used is also a factor here, as noted later in these instructions.

 **This carburetor is not fitted with a throttle stop screw. Instead, idling speed is adjusted by means of the throttle trim lever on the transmitter.**

This enables the full r.p.m. range, from idling to full power, to be controlled by the throttle stick, and then allows the engine to be stopped, from the transmitter, by closing the throttle completely with the trim lever.

Set up the throttle linkage as follows:

With the transmitter throttle trim lever fully retarded, adjust the throttle servo linkage so that the throttle rotor is (a) fully open when the transmitter throttle stick is fully advanced and (b) fully closed (i.e. engine stopped) when the stick is fully retarded. The idling speed is then set by advancing the throttle trim lever to the point where the engine runs, steadily and reliably, at the desired idling speed.

- Ⓑ As a safety measure, first check the transmitter controls, including the throttle stick and trim lever positions, and hold the main rotor securely before starting the engine.
- Ⓒ Warm the engine by allowing it to idle for about 30 seconds. If the engine stops, advance the throttle trim lever slightly to increase the idling rpm. Then open the throttle sufficiently to 'float' the model above the ground.

Ⓓ If, at this time, the engine is slow to pick up and produces an excess of exhaust smoke, the mixture is too rich. Correct this condition by turning the Mixture Control Screw clockwise. If the mixture is extremely rich, engine rpm will become unstable : opening the throttle will produce a great deal of smoke and rpm may drop suddenly or the engine may stop. This condition may also be initiated by an excessively prolonged warming-up period.

Ⓔ If, on the other hand, the mixture is too lean, this will be indicated by a marked lack of exhaust smoke and a tendency for the engine to cut out when the throttle is opened. In this case, turn the Mixture Control Screw counter-clockwise to enrich the mixture.

Ⓕ Turn the Mixture Control Screw 5 degrees at a time.

Ⓖ Having provisionally set the idle mixture, the next step is to adjust the mixture for hovering flight.

- Ⓕ Hover the model and actuate the throttle to observe response over the medium speed range. If the engine smokes excessively and throttle response is poor, the mixture is too rich ; in which case, land the model and turn the Needle Valve clockwise. Do not close the Needle Valve too much, keeping it a little on the rich side at this stage.
- ① If, on the other hand, hovering is not stable and response to the throttle is over-sensitive, or if the engine tends to overheat, this indicates that the mixture is too lean and should be corrected by turning the Needle Valve counter-clockwise.
- Ⓧ When satisfactory hovering flight has been achieved, land the model again and re-check the engine's idling qualities.
- Ⓝ After about 10 seconds of idling, open the throttle to 'float' the model. If the transition is smooth, the idle mixture is O.K. If the symptoms of either rich or lean running are observed, readjust the Mixture Control Screw accordingly.
- Ⓛ Now adjust the Needle Valve to achieve the best performance when the model is flying at full throttle. If, at full throttle, acceleration is poor, the

exhaust unduly smoky and the model fails to reach expected straight line speed, the mixture is too rich and the Needle Valve setting will need to be reduced. If, however, after smoothly accelerating to satisfactory high-speed straight and level flight, power is lost when the model is pulled up into a climb, the mixture is too lean. In this case, land the model immediately and readjust Needle Valve to a

richer setting.

- Ⓜ Now re-check hovering performance and, if necessary, fine-tune the mixture for hovering flight.
- Ⓝ For helicopters, good throttle response at medium r.p.m. (e.g.hovering speeds) is most important, since this is a power range widely used in helicopter flight. The optimum fuel/air mixture strength at medium speeds is dependent on obtaining balanced adjustment of both the Needle Valve and the Mixture Control of both the Needle Valve and the Mixture Control Valve. If both controls are already at their optimum setting, some modification to these settings may be necessary to achieve satisfactory mid-range throttle response, but such readjustments should only be made within the range where idling reliability and high-speed performance are not unduly compromised.

Readjustments should therefore be carried out as follows:

- Ⓒ If the mid-range throttle response is not rapid and positive (indicating a rich mid-range mixture), turn the Needle Valve 2 or 3 clicks clockwise, or turn the Mixture Control Screw 1-3 degrees clockwise.
- ⒫ If, on the other hand, the response to mid-range throttle movement is too sensitive (indicating a lean mid-range mixture), turn the Needle Valve 2 or 3 clicks counter-clockwise or turn the Mixture Control Screw 1-3 degrees counter-clockwise.
- Ⓖ Throttle response at hovering speeds is also affected by the relationship of the main rotor pitch angle to throttle opening. If the optimum mid-range throttle response cannot be obtained by the carburettor adjustments described above, try adjusting the helicopter's pitch control characteristics.

---

## SUBSEQUENT READJUSTMENTS

Once the engine has been run-in and the carburetor controls properly set up, it should be unnecessary to alter the mixture settings, except to make minor adjustments to the Needle Valve occasionally, to take account of variations in climatic conditions.

The use of a different fuel, however, particularly one containing more, or less, nitromethane and / or a different type or proportion of lubricating oil, is likely to call for some readjustment of the Needle-Valve.

Remember that, as a safety measure, it is advisable to increase the Needle Valve opening by an extra half-turn counter-clockwise, prior to establishing a new setting. The same applies if the silencer type is changed. A different silencer may alter the exhaust pressure applied to the fuel feed and call for a revised Needle-Valve setting.

The use of a different glowplug, or changes to the mainrotor and its pitch angles may also require compensating carburetor readjustments.

## CARBURETOR CLEANLINESS

The correct functioning of the carburetor depends on its small fuel orifices remaining clear.

The minute particles of foreign matter that are present in any fuel can easily partially obstruct these orifices and upset mixture strength so that engine performance becomes erratic and unreliable.

It is recommended that fuel is passed through a filter when the tank is filled and that a good in-line filter is installed between the fuel tank and carburettor and, furthermore, that this filter is frequently cleaned to remove dirt and lint that accumulates on the filter screen.

Finally, occasionally remove the needle-valve holder from the carburetor as shown in Photo and extract any remaining foreign matter that may have lodged in the location shown in Photo, right.

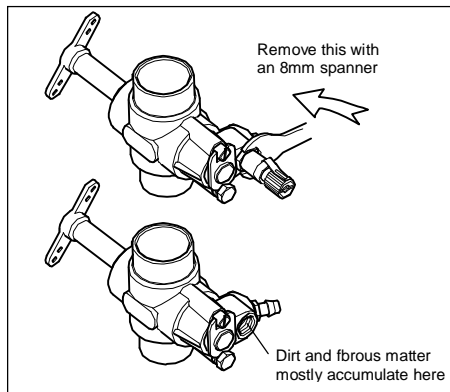

# ADJUSTING CHART

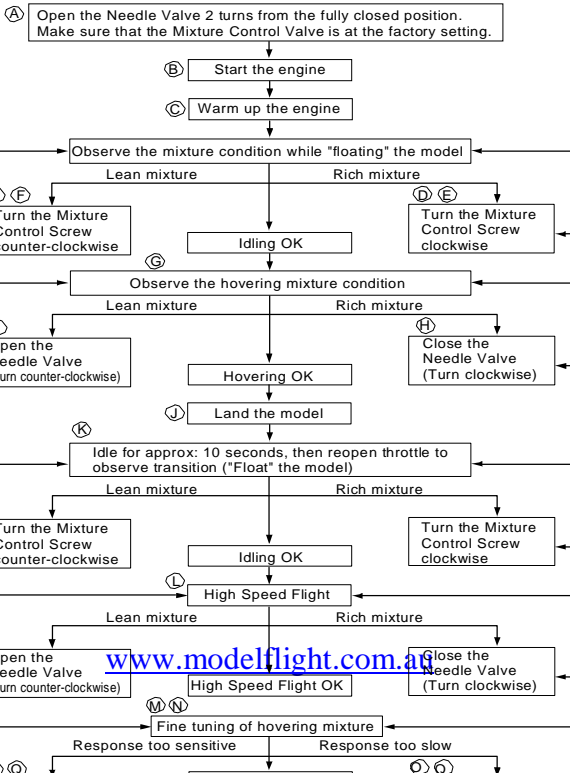

---

## INSTALLATION OF THROTTLE SERVO

After the engine in the helicopter, please observe the following recommendations when linking the throttle servo to the carburetor.

Locate the servo so that its output arm and the throttle pushrod are, as closely as possible, directly in line with carburetor's throttle arm, as shown.

Throttle control rod A and B should be equal of length. Set the linkage so that the servo output arm and throttle arm become parallel when the throttle stick on the transmitter is at middle position. If differential throttle movement is required, make necessary adjustment of the transmitter.

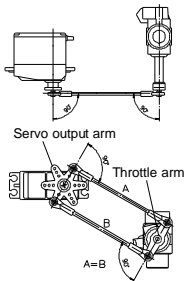

---

## CARE AND MAINTENANCE

1. The minute particles of foreign matter, that are present in any fuel may, by accumulating and partially obstructing fuel flow, cause engine performance to become erratic and unreliable.

O.S. 'Super-Filters' (large and small) are available, as optional extras, to deal with this problem.

One of these filters, fitted to the outlet tube inside

your refueling container, will prevent the entry of foreign material into the fuel tank. It is also recommended that a good in-line filter be installed between the tank and carburetor.

2. Do not forget to clean the filters regularly to remove dirt and lint that accumulate on the filter screens. Also, clean the carburetor itself occasionally.

3. At the end of each operating session, drain out any fuel that may remain in the fuel tank. Next, energize the glowplug and try to restart the engine to burn off any fuel that may remain inside the engine. Repeat this procedure until the engine fails to fire.

Remove the glowplug and eject any remaining fuel/oil residue by rotating the engine with an electric starter for 4 to 5 seconds while the engine is still warm.

4. Finally, inject some after-run oil into the engine.

Rotate the engine a few times by hand, to make sure that it is free, and then with an electric starter for 4 to 5 seconds to distribute the oil to all the working

### Note:

**Do not inject after-run oil into the carburetor as this may cause the O-rings inside the carburetor to deteriorate.**

These procedures will reduce the risk of starting difficulties and of internal corrosion after a period of storage.

# EXPLODED VIEW

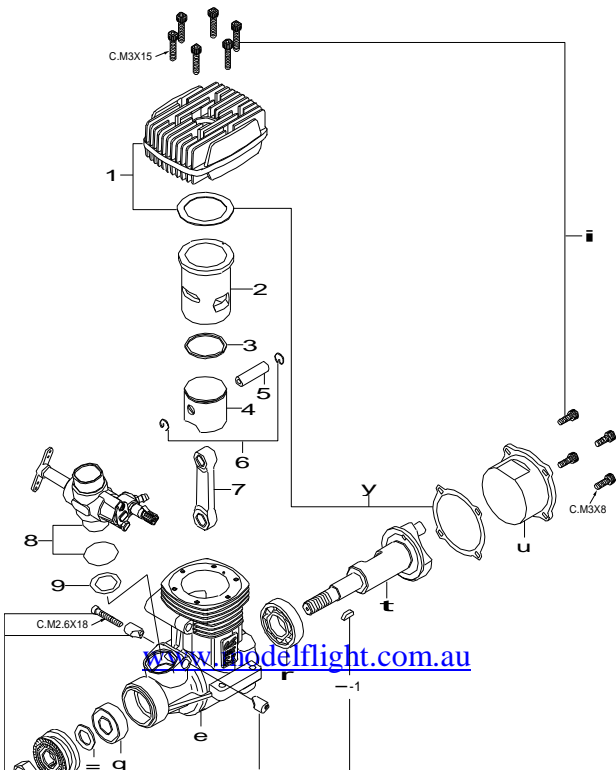

## ENGINE PARTS LIST

No.	Code No.	Description
<b>1</b>	25204000	Heatsink Head
<b>2</b>	25203100	Cylinder Liner
<b>3</b>	25303400	Piston Ring
<b>4</b>	25203200	Piston
<b>5</b>	25206000	Piston Pin
<b>6</b>	25217000	Piston Pin Retainer
<b>7</b>	25205000	Connecting Rod
<b>8</b>	25281000	Carburetor Complete 40E
<b>9</b>	23818190	Carburetor Sealing Washer
<b>0</b>	23210007	Propeller Nut
<b>-</b>	27708010	Drive Washer
<b>--1</b>	27708200	Woodruff Key
<b>=</b>	46120000	Thrust Washer
<b>q</b>	26731002	Crankshaft Ball Bearing(Front)
<b>w</b>	23981700	Carburetor Retainer Assembly
<b>e</b>	25201000	Crankcase
<b>r</b>	26730010	Crankshaft Ball Bearing(Rear)
<b>t</b>	25202000	Crankshaft
<b>y</b>	25214000	Gasket Set
<b>u</b>	25207000	Cover Plate
<b>i</b>	25613000	Screw Set
	71608001	Glow Plug No.8

## CARBURETOR PARTS LIST & EXPLODED VIEW

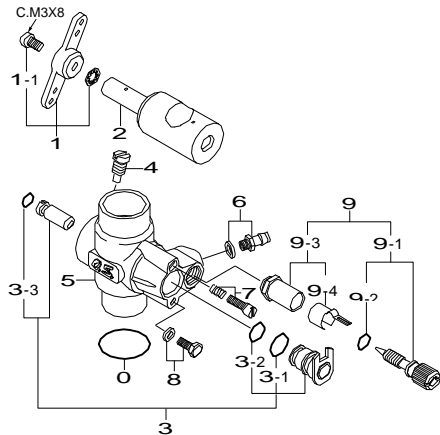

= Type of screw

C . . . Cap Screw M . . . Oval Fillister-Head Screw

F . . . Flat Head Screw N . . . Round Head Screw S . . . Set

No.	Code No.	Description
1	27381410	Throttle Lever Assembly
1	22826131	Throttle Lever Retaining Screw
2	25281200	Carburetor Rotor
3	25281600	Mixture Control Valve Assembly
3-1	27881810	"O" Ring (L) (2pcs.)
3-2	27881800	"O" Ring (S) (2pcs.)
3-3	27881820	"O" Ring (L) (2pcs.)
4	45581820	Rotor Guide Screw
5	25281100	Carburetor Body
6	22681953	Fuel Inlet
7	27881330	Mixture Control Screw
8	27681340	Mixture Control Valve Stopper Assembly
9	27981900	Needle Valve Assembly
9-1	27981910	Needle
9-2	24981837	"O" Ring (2pcs.)
9-3	27381940	Needle Valve Holder Assembly
9-4	26711305	Ratchet Spring
0	29015019	Carburetor Rubber Gasket

The specifications are subject to alteration for improvement without notice.

## THREE VIEW DRAWING    Dimensions(mm)

### SPECIFICATIONS

Displacement	8.17 cc (0.499 cu.in.)
Bore	22.0mm (0.866 in.)
Stroke	21.5mm (0.847 in.)
Practical R.P.M.	2,000~20,000 r.p.m.
Power output	1.8 bhp / 17,000 r.p.m.
Weight	413g(14.58oz.)

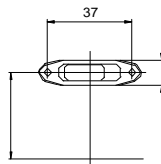
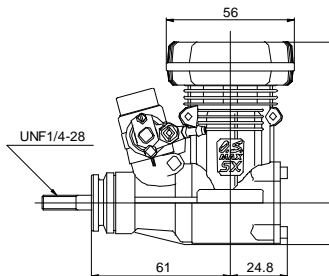
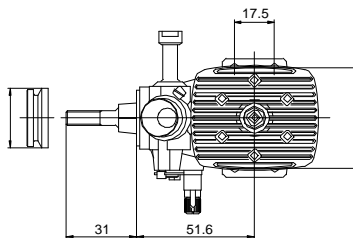
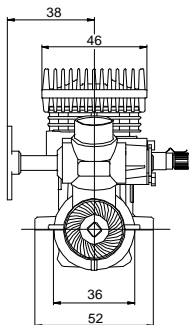

---

## O.S. GENUINE PARTS & ACCESSORIES

---

### O.S. GLOW PLUGS

No.8 (71608001)    A5 (71605100)



### IN-FLIGHT CONTROL NEEDLE VALVE (71705000)



---

### SUPER FILTER

(72403050)



(L)

### LOCK WASHER(10set)

M3 (55500002)

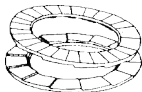

### LONG SOCKET WRENCH

WITH PLUG GRIP (71521000)

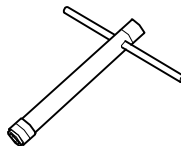

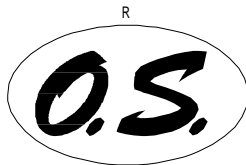

***O.S. ENGINES*** MFG.CO.,LTD.

6-15 3-Chome Imagawa Higashisumiyoshi-ku  
Osaka 546-0003, Japan TEL. (06) 6702-0225

FAX. (06) 6704-2722

URL : <http://www.os-engines.co.jp>

© Copyright 2000 by O.S.Engines Mfg. Co., Ltd. All rights reserved. Printed in Japan.

110103

[www.modelflight.com.au](http://www.modelflight.com.au)