

***O.S. ENGINE* MAX-12/15LD, LD-X SERIES**

OWNER'S INSTRUCTION MANUAL

It is of vital importance, before attempting to operate your engine, to read the general **'SAFETY INSTRUCTIONS AND WARNINGS'** section on pages 2-5 of this booklet and to strictly adhere to the advice contained therein.

- Also, please study the entire contents of this instruction manual, so as to familiarize yourself with the controls and other features of the engine.
- Keep these instructions in a safe place so that you may readily refer to them whenever necessary.
- It is suggested that any instructions supplied with the vehicle, radio control equipment, etc., are accessible for checking at the same time.

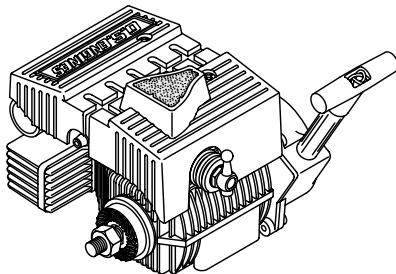

CONTENTS

SAFETY INSTRUCTIONS AND WARNINGS ABOUT YOUR O.S. ENGINE	2~5	IF THE ENGINE FAILS TO START	15
INTRODUCTION, BASIC ENGINE PARTS	6	FINAL ADJUSTMENT	16~17
ENGINE SHIELD, INSTALLATION	7~8	CARBURETOR CLEANLINESS	17~18
THROTTLE LINKAGE AIR CLEANER	8~9	CARE AND MAINTENANCE PARTS REPLACEMENT	18~19
NOTES CONCERNING THE RECOIL STARTER	9~10	EXPLODED VIEW & ENGINE PARTS LIST	20~23
GLOWPLUGS	10~11	CARBURETOR EXPLODED VIEW & PARTS LIST	24
TOOLS, ACCESSORIES, etc.	11~12	O.S. GENUINE PARTS & ACCESSORIES	25
CARBURETOR CONTROLS	12	THREE VIEW DRAWING	26~27
STARTING THE ENGINE & RUNNING-IN('Breaking-in)	13~15	MEMO	28

SAFETY INSTRUCTIONS AND WARNINGS ABOUT YOUR O.S. ENGINE

Remember that your engine is not a "toy", but a highly efficient internal-combustion machine whose power is capable of harming you, or others, if it is misused.

As owner, you, alone, are responsible for the safe operation of your engine, so act with discretion and care at all times.

If at some future date, your O.S. engine is acquired by another person, we would respectfully request that these instructions are also passed on to its new owner.

- The advice which follows applies basically to **ALL MODEL ENGINES** and is grouped under two headings according to the degree of damage or danger which might arise through misuse or neglect.



WARNINGS

These cover events which might involve serious (in extreme circumstances, even fatal) injury.



NOTES

These cover the many other possibilities, generally less obvious sources of danger, but which, under certain circumstances, may also cause damage or injury.



WARNINGS

- Model engine fuel is poisonous. Do not allow it to come into contact with the eyes or mouth. Always store it in a clearly marked container and out of the reach of children.



- Model engine fuel is also highly flammable. Keep it away from open flame, excessive heat, sources of sparks, or anything else which might ignite it. Do not smoke or allow anyone else to smoke, near to it.



- Never operate your engine in an enclosed space. Model engines, like automobile engines, exhaust deadly carbon-monoxide. Run your engine only in an open area.

- Model engines generate considerable heat. Do not touch any part of your engine until it has cooled. Contact with the muffler (silencer), cylinder head or exhaust header pipe, in particular, may result in a serious burn.





NOTES

- This engine is intended for model cars. Do not attempt to use it for any other purpose.
- Mount the engine in your model securely, following the manufacturers' recommendations, using appropriate screws and locknuts.
- Fit an effective silencer (muffler). Frequent close exposure to a noisy exhaust (especially in the case of the most powerful highspeed engines) may eventually impair your hearing and such noise is also likely to cause annoyance to others over a wide area.
- The wearing of safety glasses is also strongly recommended.
- Take care that the glowplug clip or battery leads do not come into contact with rotating parts. Also check that the linkage to the throttle arm is secure.
- For their safety, keep all onlookers (especially small children) well back (at least 20 feet or 6 meters) when preparing your model for running.



NOTES

- To stop the engine, fully retard the throttle stick and trim lever on the trans-mitter, or, in an emergency, cut off the fuel supply by pinching the fuel delivery tube from the tank.
- Do not attempt to disassemble the recoil starter of the 12LD-X and 15LD-X. If you do so, the very strong spring inside will be suddenly ejected. This can be very dangerous.
- Do not extend the starter cord more than 45cm (18"). Do not abruptly release the operating handle. Allow the cord to rewind smoothly while still holding the handle.
- Pull the operating handle straight out when starting the engine, so that the cord does not rub against the vehicle body or engine. This will help prevent the cord from being damaged by abrasion or engine heat.
- Warning! Immediately after a glowplug-ignition engine has been run and is still warm, conditions sometimes exist whereby it is just possible for the engine to abruptly restart if it is rotated over compression WITHOUT the glowplug battery being reconnected.

INSTALLING THE GLOWPLUG

Fit washer to glowplug and insert carefully into cylinder-head, making sure that it is not cross-threaded before tightening firmly.

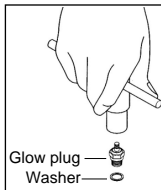

ENGINE SHIELD

If the engine shield has to be removed, e.g. for access to the carburettor, etc., apply a little LOCTITE liquid polymer sealant to the two crankcase lug screw holes when reinserting the fixing screws. Use LOCTITE sparingly, as excess sealant will have a deleterious effect on the shield material.

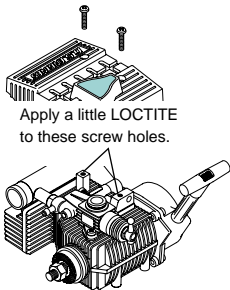

INSTALLATION OF ENGINE

Make sure that the chassis is flat and free from flaws or dirt. The recommended screws for securing the engine to the chassis are 3mm (8 to 10mm long).

In the case of the 12/15LD-X, fit the engine mount spacers between the engine and chassis to avoid interference between starter housing and chassis.

Divide the spacers into lengths.

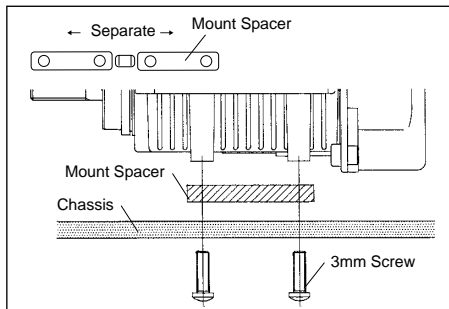

INSTALLATION OF E-1000 SILENCER (12/15LD(T)-LD-X(T))

MODIFICATION OF O.S. E-1000 SILENCER FOR PRESSURIZED FUEL SUPPLY

- Fit the nipple (supplied) to the silencer, applying heat-resistant epoxy sealant at the roof of the fitting (See sketch).
- Before installing the engine in the chassis, secure the silencer to the engine with M3X27mm screws.

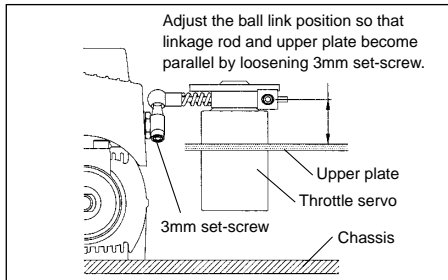

THROTTLE LINKAGE

The throttle-arm ball-link is adjustable. Loosen 3mm set-screw and adjust the link so that linkage rod and upper plate become parallel, and then retighten it securely.

If the linkage rod and upper plate are not parallel, throttle valve will not move smoothly and may damage the carburettor.

AIR CLEANER

The air cleaner of this engine is integrated with the engine shield. It contains a specially impregnated filter element which prevents highly damaging dust and dirt from being drawn into the engine through the carburettor.

An O-ring is fitted between the engine shield and carburettor to exclude air leaks.

FILTER ELEMENT AND ITS REPLACEMENT

- The elements are already impregnated with a special filter oil. As this oil is very sticky, take care, when handling them, to prevent dust or dirt from adhering to the elements. If your fingers become contaminated, wash them with soap and water.
- During storage, the filter oil may become unevenly dispersed through the element. This will be indicated if the blue colour of the element material appears patchy. In this case, place element in a small plastic bag and gently rub it between finger and thumb to redistribute the oil.
- When fitting the element, be careful not to leave spaces through which foreign matter may be drawn.
- It is advisable to replace the element with a new one after not more than one hour of running time. Always remove contaminated element carefully, to ensure that dirt cannot enter the carburettor.

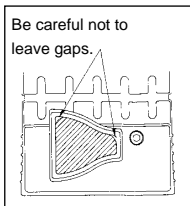

NOTES CONCERNING THE RECOIL STARTER

(12/15LD-X ONLY)

REMINDER!

- ◆ Do not attempt to disassemble the recoil starter. If you do so, the very strong spring inside will be suddenly ejected. This can be very dangerous.
- ◆ Do not extend the starter cord more than 45cm(18"). Do not abruptly release the operating handle. Allow the cord to rewind smoothly while still holding the handle.
- ◆ Pull the operating handle straight out when starting the engine, so that the cord does not rub against the vehicle body or engine.
- ◆ This will help prevent the cord from being damaged by abrasion or engine heat.
- ◆ Try to avoid spilling fuel over the starter unit and its cord. Some fuels have a detrimental effect on these parts.

- ◆ **The starter prevents the engine from being rotated in the wrong direction. The unit will be damaged if you attempt to force the fly-wheel in the opposite direction (i.e. clockwise when viewed from the crankshaft end).**

NOTE:

Because, in the interests of personal safety, dismantling of the starter mechanism is strongly discouraged, the Recoil Starter is available for replacement only as a pre-assembled unit.

However, some related parts, such as Starting Shaft and Rear Adaptor, are obtainable separately. (See Parts List.)

GLOWPLUGS

Since the compatibility of glowplug and fuel may have a marked effect on performance and reliability, it may be worthwhile to choose the R/C type plug found most suitable after tests. Recommended O.S. plugs are No.8, A3, and A5. Carefully fit plug finger-tight, before final tightening with the correct size plug wrench.

The role of the glowplug

With a glowplug engine, ignition is initiated by the application of a 1.5-volt power source. When the battery is disconnected, the heat retained within the combustion chamber remains sufficient to keep the plug filament glowing, thereby continuing to keep the engine running. Ignition timing is 'automatic' : under reduced load, allowing higher rpm, the plug becomes hotter and, appropriately, fires the fuel/air charge earlier; conversely, at reduced rpm, the plug become cooler and ignition is retarded.

Glowplug life

Particularly in the case of very high performance engines, glowplugs must be regarded as expendable items. However, plug life can be extended and engine performance maintained by careful use, i.e.:

- Fit a plug suitable for the engine.
- Use fuel containing a moderate percentage of nitromethane unless more is essential for racing events.
- Do not run the engine too lean and do not leave the battery connected while adjusting the needle.

When to replace the glowplug

Apart from when actually burned out, a plug may need to be replaced because it no longer delivers its best performance, such as when:

- Filament surface has roughened and turned white.
- Filament coil has become distorted.
- Foreign matter has adhered to filament or plug body has corroded.
- Engine tends to cut out when idling.
- Starting qualities deteriorate.

TOOLS, ACCESSORIES, etc.

The following items are necessary for operating the engine.

FUEL

Use only top quality methanol-based model engine fuel. For consistent performance and long engine life, it is advisable to use fuel containing AT LEAST 18% lubricant. This engine is designed to run on both low and high nitromethane content fuels, i.e. from mild mixtures containing a few percent of nitromethane, up to high-speed racing fuels containing 40% nitromethane. Generally, power output is increased—up to a certain point—as the nitromethane content of the fuel is increased.

As a starting point, we recommend a fuel containing 10-20% nitromethane, changing to a fuel containing more nitro only if necessary. When the nitro content of the fuel is increased or the brand of fuel is changed, it is advisable to initially run the engine with a richer needle-valve setting, so that the optimum setting for the new fuel may be rechecked as described in the RUNNING-IN paragraphs. When engines are run at very high speeds and on high-nitro fuels, glowplug elements do not last so long.

Reminder!

 **Model engine fuel is poisonous. Do not allow it to come into contact with the eyes or mouth. Always store it in a clearly marked container and out of the reach of children.**

 **Model engine fuel is also highly flammable. Keep it away from open flame, excessive heat, sources of sparks, or anything else which might ignite it.**

GLOWPLUG BATTERY

The power source for heating the glowplug may be either a large heavy-duty 1.5Volt dry cell, or a 2-Volt rechargeable lead-acid cell with extended leads (or a resistance) to reduce the applied voltage to

BATTERY LEADS

These are used to conduct current from the battery to the glowplug. For convenience, special leads with a suitable clip to fit the glowplug terminal, are commercially available.

LONG SOCKET WRENCH

Recommended for easy removal and replacement of the angled and recessed glowplug, the O.S. Long Socket Wrench incorporates a special grip. (See Parts List)

FUEL BOTTLE OR PUMP

For filling the fuel tank, a simple, polyethylene "squeeze" bottle, with a suitable spout, is required. Alternatively, one of the purpose-made manual or electric fuel pumps may be used to transfer fuel directly from your fuel container to the fuel tank.

SILICONE TUBING

Heatproof silicone tube of approx. 5mm o.d. and 2mm i.d. is required for the connection between the fuel tank and engine.

ELECTRIC STARTER AND STARTER BATTERY

Use an electric starter with 12-volt battery for starting the MAX-12LD and MAX-15LD.

CARBURETOR CONTROLS (10F)

Three adjustable controls are provided on this carburetor.

- **The Needle-Valve:**

For adjusting the mixture strength when the throttle is fully open.

- **The Mixture Control Screw:**

For adjusting the mixture strength at part-throttle and idling speeds, to obtain steady idling and smooth acceleration to mid speeds.

- **The Throttle Stop Screw:**

For setting the minimum idling speed.

NOTE:

Readjustment may be necessary, occasionally to allow for changes in fuel formulae, gear ratio or clutch engagement point.

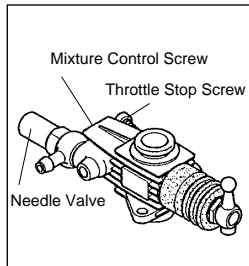

STARTING THE ENGINE & RUNNING-IN ('Breaking-in')

PRESSURIZED FUEL SYSTEM

- The somewhat violent changes of vehicle attitude that occur in off-road running, combined with the fact that, in buggy type cars, the fuel tank is often located some distance from the carburetor, means that fuel 'head' at the carburetor can vary and upset running. Therefore, it is recommended that a muffler pressurized fuel feed system be used.
- Never run your vehicle without fitting the air cleaner. Dust and dirt that may otherwise be drawn into the engine will rapidly shorten its life.

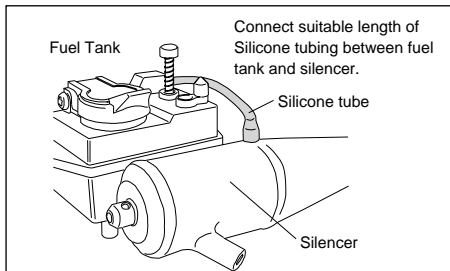

The following procedure is suitable for these engines when the O.S. T-1020 tuned silencer and a fuel containing up to 30% nitromethane are used.

- Use the same fuel as is to be employed for all initial running and containing NOT LESS THAN 18% lubricant.
- Temporarily remove the glowplug to check that it glows bright red when energized.
- Re-check the needle-valve and throttle settings. Turn the needle-valve clockwise slowly and gently until it stops. This is the fully closed position. Do not use force to turn the needle-valve beyond this point.

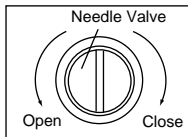

- Open the Needle-Valve 2 turns from the fully closed position.
- Switch on the transmitter and receiver and set the throttle very slightly opened from the idling position.

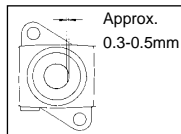

- DO NOT energize glowplug, but apply electric starter to draw fuel to carburetor.

- Now connect glowplug battery lead to heat the plug filament and start the engine.

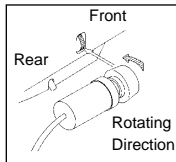

■ In case of the 12/15LD-X

- Push the choke button on the fuel tank several times to deliver the fuel to the carburetor. (Do not over-prime or the recoil starter cannot be pulled.)
- Pull the starter handle briskly straight out several times to start the engine.

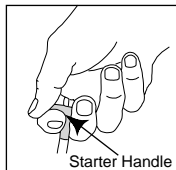

Remember!

It is vitally important to set the throttle at the correct position before attempting to start the engine. If the engine is allowed to run with the throttle too far open under "no load" conditions, it will rapidly overheat and may be seriously damaged.

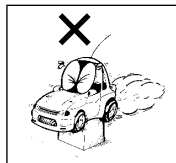

- When the engine starts, first allow it to operate in short runs at the very rich starting settings, with the glowplug battery still connected and with its driving wheels clear of the ground. The rich mixture will, under these conditions, provide adequate lubrication and cooling, indicated by profuse smoke from the exhaust.

- Next, disconnect the glowplug battery and try running the car on the track. If the engine stalls, open the throttle fractionally, but try to keep the engine running as rich as possible: if it stops because of being excessively over-rich, close the Needle-Valve 30° and try again.

- Run the car on the track until one tank of fuel has been consumed, then close the Needle-Valve 30° and run the car for another full tank of fuel.

Repeat this procedure until 5 more tanks of fuel have been consumed, during which time the throttle may be opened for brief bursts of increased power. If the engine stops at medium speeds, close the Mixture Screw 45-90°.

Repeat this procedure until 5 more tanks of fuel have been consumed, during which time the throttle may be opened for brief bursts of increased power. If the engine stops at medium speeds, close the Mixture Screw 45-90°.

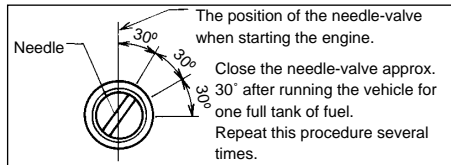

- To stop the engine, close the throttle to idling speed, then shut it off completely with the trim lever on the transmitter. To cut off the fuel supply, pinch the fuel delivery tube to the carburetor.

Remember!

If the engine should need to be disassembled (e.g. for cleaning or minor parts replacement) it is advisable to return the Needle-Valve to the original rich, starting setting and check whether further running-in time is required before the car is raced again. In the event of any major working parts (e.g. piston/cylinder liner assembly) being replaced, the complete running-in should be repeated.

IF THE ENGINE FAILS TO START

Check the following:

- Glowplug battery discharged or glowplug defunct.
- Fuel not reaching carburetor.
- Engine flooded.

Do not over-prime. (This could also cause hydraulic lock and damage the engine on application of the electric starter.)

Remove glowplug, close needle-valve and apply starter to pump out surplus fuel. At this time cover the plug hole with a rag so that splashing out fuel may not come into your eyes or mouth.

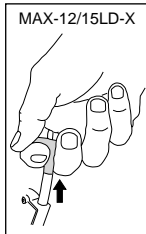

FINAL ADJUSTMENT

- Run the vehicle (with throttle fully open) over the longest available straight course, in order to observe the model's speed. Next return the car to the starting point, close the Needle-Valve 30° and repeat the run, taking note of the improvement in performance. Continue with further runs, gradually reducing the Needle-Valve setting and aiming to achieve the highest straight-line speed. Remember, however, that, if the Needle-Valve is shut down too far, the engine will overheat and, accompanied by visibly diminished exhaust smoke, the model will lose speed. At this point, throttle down immediately, stop the vehicle and reopen the Needle-Valve 30°.
- Having established the optimum Needle-Valve setting, check the Mixture Control Valve setting as follows.
- With the engine running, close the throttle and allow it to idle for about five seconds, then reopen the throttle fully. If, at this point, the engine puffs out an excessive amount of smoke and the vehicle does not accelerate smoothly and rapidly, it is probable that the idling mixture is too rich.

- In this case, turn the Mixture Control Valve clockwise 45~90°. If, on the other hand, the engine tends to speed up momentarily and then cut out abruptly when the throttle is opened, the idling mixture is too lean. Correct this by turning the Mixture Control Valve counter-clockwise 45~90°.

NOTE:

Mixture Control Valve adjustment should be made in steps of not more than 45~90°, carefully checking the effect, on throttle response, of each small adjustment.

- Carry out adjustments patiently, under actual running conditions, until the engine responds quickly and positively to the throttle control.

Warning!

Mixture adjustments (whether via the Mixture Control Valve, or the Needle-Valve) cannot be made accurately under 'no-load' conditions, which, in any case, are not advised, since such operation carries the risk of seriously damaging the engine through over-revving and overheating.

- With the optimum mixture control position, light smoke is visible during high speed running, and the engine revolutions increase smoothly during acceleration. Remember that, if the engine is operated with the fuel/air mixture slightly too lean, it will overheat and run unevenly. As with all engines, it is advisable to set both needle-valve and mixture control screw very slightly on the rich side of the best rpm setting, as a safety measure.
- If the engine runs too fast with the throttle closed, the throttle stop screw should be turned counter-clockwise to allow the throttle opening to be reduced.
- Finally, beyond the nominal break-in period, a slight readjustment toward a leaner needle setting may be required to maintain performance.

CARBURETOR CLEANLINESS

The correct functioning of the carburetor depends on its small fuel orifices remaining clear.

■ BALL LINK AND SLIDE VALVE EXTENSION

It is seldom necessary to separate the slide-valve extension from the slide-valve itself. For cleaning, withdraw this complete sub-assembly from the carburetor body after removing the slide-valve guide screw. Then wash with methanol or glow-fuel.

(Note: take care not to lose the guide screw; it is a special one.)

When it is necessary to adjust the ball-link position, loosen the ball-link retaining screw with a 1.5mm hexagon key, re-align the ball-link and re-tighten the screw firmly.

■ REALIGNMENT OF MIXTURE CONTROL VALVE

In the course of making carburetor adjustments, it is just possible that the Mixture Control Valve may be inadvertently screwed in or out too far and thereby moved beyond its effective adjustment range. Its basic position can be found by first rotating the Mixture Control Valve until its slotted head is flush with the carburetor body. The valve is then screwed in exactly 2.5 turn to re-establish its neutral position.

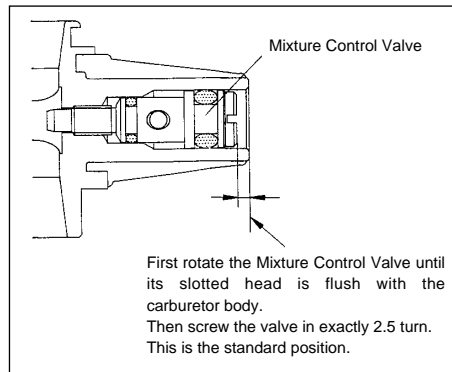

CARE AND MAINTENANCE

1. The minute particles of foreign matter, that are present in any fuel may, by accumulating and partially obstructing fuel flow, cause engine performance to become erratic and unreliable. One of these filters, fitted to the outlet tube inside your refueling container, will prevent the entry of foreign material into the fuel tank. It is also recommended that a good in-line filter be installed between the tank and carburetor.
2. Do not forget to clean the filters regularly to remove dirt and lint that accumulate on the filter screens. Also, clean the carburetor itself occasionally.
3. At the end of each operating session, drain out any fuel that may remain in the fuel tank. Afterwards, energize the glow-plug and try to restart the engine, to burn off any fuel that may remain inside the engine. Repeat this procedure until the engine fails to fire. Do this while the engine is still warm.

4. Then, inject some after-run oil into the engine, and rotate the engine with an electric starter for 4 to 5 seconds to distribute the oil to all the working parts.

Note:

Do not inject after-run oil into the carburetor as this may cause the O-rings inside the carburetor to deteriorate. These procedures will reduce the risks of starting difficulties or corrosion after a period of storage.

5. Finally, when cleaning the exterior of the engine, use methanol or kerosene. Do not use gasoline or any solvent that might damage the silicone fuel tubing.

Caution:

The rear crankshaft bearing of this engine uses a special plastic retainer. If the front housing needs to be heated to remove or replace the bearing, do not allow the bearing to exceed 120°C (248°F), otherwise it may be damaged and rendered unserviceable.

PARTS REPLACEMENT

Over a long period, depending on how well your engine is protected from the ingress of harmful dust and grit, and other causes of wear and tear, loss of performance may eventually occur in the form of reduced power, unstable idling, overheating, etc. Inspection may then reveal that the replacement of ball-bearings, connecting rod, etc. is called for. Contact the O.S. distributor in your country for replacement parts, or full service.

MAX-12, 15LD/LD(T) EXPLODED VIEW

—20—

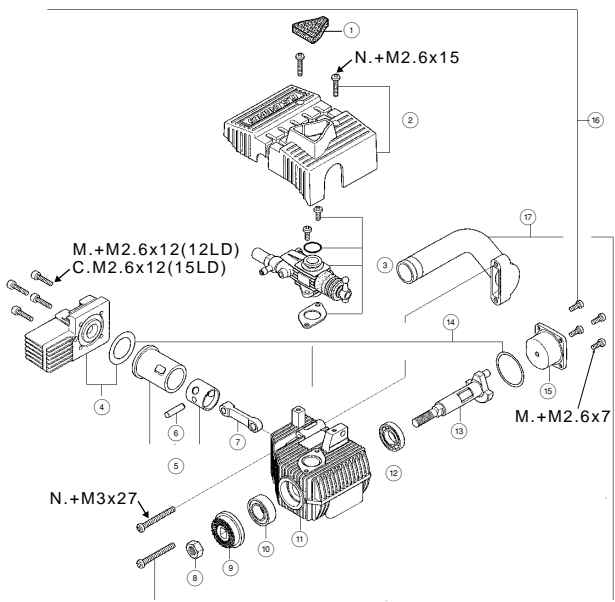

* Type of screw C...Cap Screw M...Oval Fillister-Head Screw
 F...Flat Head Screw N...Round Head Screw S...Set Screw

MAX-12,15LD/LD(T) ENGINE PARTS LIST

No.	Code No.	Description
①	7 2403 420	104 Filter Elements (3pcs.)
②	7 2403 410	Engine Shield 【12LD】
	7 2403 510	Engine Shield 【15LD】
③	2 1183 000	Carburetor Complete (Type 10F)
④	2 1154 000	Heatsink Head 【12LD】
	2 1554 000	Heatsink Head 【15LD】
⑤	2 1203 011	Cylinder & Piston Assembly 【12LD】
	2 1503 000	Cylinder & Piston Assembly 【15LD】
⑥	2 1206 000	Piston Pin 【12LD】
	2 1706 000	Piston Pin 【15LD】
⑦	2 1205 040	Connecting Rod
⑧	2 0810 007	Propeller Nut
⑨	2 1408 000	Drive Hub
⑩	2 2631 019	Crankshaft Ball Bearing (Front)
⑪	2 1151 000	Crankcase 【12LD】
	2 1551 000	Crankcase 【15LD】
⑫	2 1230 000	Crankshaft Ball Bearing (Rear)
⑬	2 1152 000	Crankshaft
⑭	2 1164 000	Gasket Set 【12LD】
	2 1524 000	Gasket Set 【15LD】
⑮	2 1157 000	Cover Plate
⑯	2 1163 000	Screw Set 【12LD】
	2 1313 030	Screw Set 【15LD】
⑰	7 2103 410	Exhaust Header Pipe
	7 1605 300	Glow Plug A3 【12LD】
	7 1608 001	Glow Plug No.8 【15LD】
	2 1325 000	E-1000 Silencer 【12/15LD(T)】

* h12/15LD(T) is supplied with E-1000 Silencer instead of exhaust header pipe.

The specifications are subject to alteration for improvement without notice.

MAX-12, 15LD-X/LD-X(T) EXPLODED VIEW

—22—

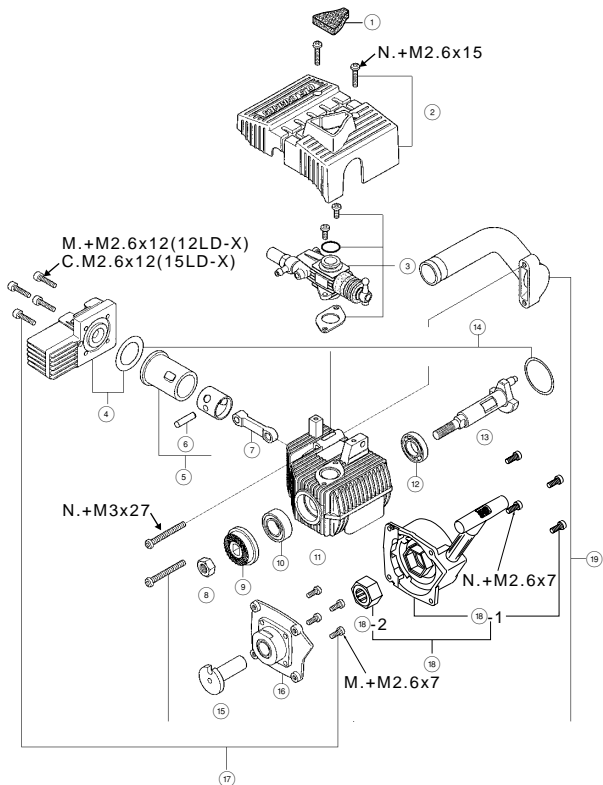

*Type of screw C...Cap Screw M...Oval Fillister-Head Screw
F...Flat Head Screw N...Round Head Screw S...Set Screw

MAX-12,15LD-X/LD-X(T) ENGINE PARTS LIST

No.	Code No.	Description
①	7 2403 420	104 Filter Elements (3pcs.)
②	7 2403 410	Engine Shield 【12LD-X】
	7 2403 510	Engine Shield 【15LD-X】
③	2 1183 000	Carburetor Complete (Type 10F)
④	2 1154 000	Heatsink Head 【12LD-X】
	2 1554 000	Heatsink Head 【15LD-X】
⑤	2 1203 011	Cylinder & Piston Assembly 【12LD-X】
	2 1503 000	Cylinder & Piston Assembly 【15LD-X】
⑥	2 1206 000	Piston Pin 【12LD-X】
	2 1706 000	Piston Pin 【15LD-X】
⑦	2 1205 040	Connecting Rod
⑧	2 0810 007	Propeller Nut
⑨	2 1408 000	Drive Hub
⑩	2 2631 019	Crankshaft Ball Bearing (Front)
⑪	2 1151 000	Crankcase 【12LD-X】
	2 1551 000	Crankcase 【15LD-X】
⑫	2 1230 000	Crankshaft Ball Bearing (Rear)
⑬	2 1152 010	Crankshaft
⑭	2 1164 000	Gasket Set 【12LD-X】
	2 1524 000	Gasket Set 【15LD-X】
⑮	2 1421 200	Starting Shaft
⑯	2 1121 100	Rear Adapter
⑰	2 1163 000	Screw Set 【12LD-X】
	2 1313 030	Screw Set 15LD-X
⑱	7 3003 000	No.5 Recoil Starter Assembly
⑱-1	7 3003 100	No.5 Recoil Starter Body
⑱-2	7 3003 200	No.5 One-way Clutch
⑲	7 2103 410	Exhaust Header Pipe
	7 1605 300	Glow Plug A3 【12LD-X】
	7 1608 001	Glow Plug No.8 【15LD-X】
	7 2404 100	Engine Mount Spacer
	2 1325 000	E-1000 Silencer 【12/15LD-X(T)】

※ 12/15LD(T) is supplied with E-1000 Silencer instead of exhaust header pipe.
The specifications are subject to alteration for improvement without notice.

10F CARBURETOR EXPLODED VIEW & PARTS LIST

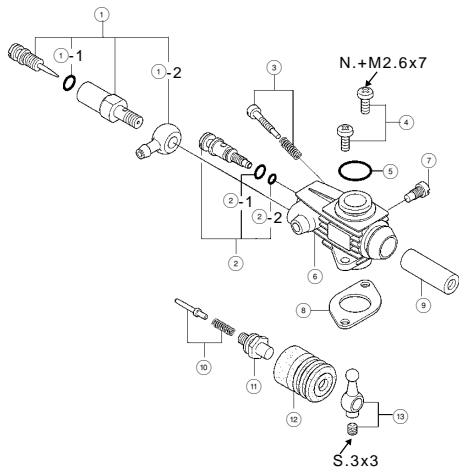

*Type of screw

C...Cap Screw M...Oval Fillister-Head Screw

F...Flat Head Screw N...Round Head Screw S...Set Screw

No.	Code No.	Description
①	2 1481 900	Needle Valve Assembly
①-1	2 7881 820	"O" Ring
①-2	2 1481 950	Universal Nipple No.12
②	2 1285 600	Mixture Control Valve Assembly
②-1	4 6066 319	"O" Ring(L)
②-2	2 2781 800	"O" Ring(S)
③	2 1285 640	Throttle Stop Screw
④	2 1183 700	Carburetor Retaining Screw
⑤	2 1181 837	"O" Ring
⑥	2 1183 100	Carburetor Body
⑦	2 1285 220	Slide Valve Guide Screw
⑧	2 1165 000	Thermo Insulator
⑨	2 1285 200	Slide Valve
⑩	2 1285 400	Metering Needle Assembly
⑪	2 1285 210	Slide Valve Extension
⑫	2 1285 520	Dust Cover
⑬	2 3818 410	Ball Link No.2

The specifications are subject to alteration for improvement without notice.

■ O.S. Glow Plug



No.8
(71608001)
A3
(71605300)
A5
(71605100)

■ Super Joint Tube 15
(72103310)



■ T-1020
Tuned Silencer
(72103020)



■ 104 Filter Elements
(72403420) (3pcs.)

■ E-1000 Silencer
For TAMIYA TGX/TG10
(21325000)



■ Long Socket Wrench
With Plug Grip
(71521000)

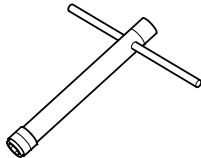

■ Dust Cap Set
φ4 (73300305)
For Carburettor Nipple
φ7 (73300712)
For T-1020 Tuned
Silencer

12/15LD THREE VIEW DRAWING

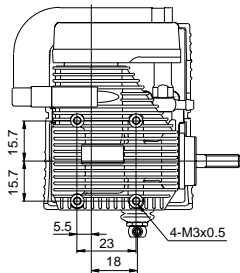
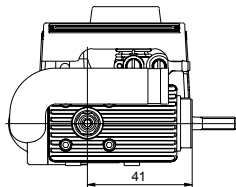

MAX-12LD SPECIFICATIONS

■ Displacement	2.11 cc(0.129cu.in.)
■ Bore	14.0 mm(0.551in.)
■ Stroke	13.7 mm(0.539in.)
■ Practical R.P.M.	3,000~30,000 r.p.m.
■ Power output	0.56 bhp / 29,000 r.p.m.
■ Weight	273g(9.64oz.)

MAX-15LD SPECIFICATIONS

■ Displacement	2.49 cc(0.152cu.in.)
■ Bore	15.2 mm(0.598in.)
■ Stroke	13.7 mm(0.539in.)
■ Practical R.P.M.	3,000~30,000 r.p.m.
■ Power output	0.68 bhp / 29,000 r.p.m.
■ Weight	273g(9.64oz.)

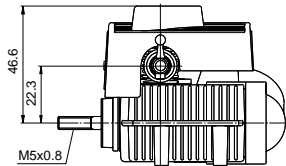

Dimensions(mm)

12/15LD-X THREE VIEW DRAWING

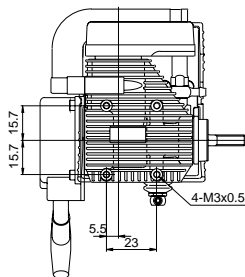
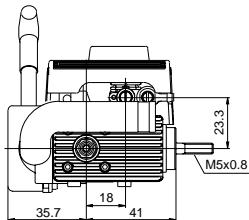

MAX-12LD-X SPECIFICATIONS

■ Displacement	2.11 cc(0.129cu.in.)
■ Bore	14.0 mm(0.551in.)
■ Stroke	13.7 mm(0.539in.)
■ Practical R.P.M.	3,000~30,000 r.p.m.
■ Power output	0.56 bhp / 29,000 r.p.m.
■ Weight	336g(11.86oz.)

MAX-15LD-X SPECIFICATIONS

■ Displacement	2.49 cc(0.152cu.in.)
■ Bore	15.2 mm(0.598in.)
■ Stroke	13.7 mm(0.539in.)
■ Practical R.P.M.	3,000~30,000 r.p.m.
■ Power output	0.68 bhp / 29,000 r.p.m.
■ Weight	336g(11.86oz.)

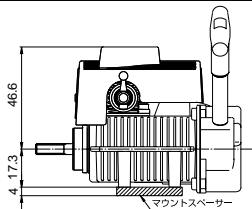

Dimensions(mm)

MEMO



O.S. ENGINES MFG.CO.,LTD.

6-15 3-Chome Imagawa Higashisumiyoshi-ku
Osaka 546-0003, Japan TEL. (06) 6702-0225

FAX. (06) 6704-2722

URL : <http://www.os-engines.co.jp>