

Mini Edge 540 3D

Eflite[™]

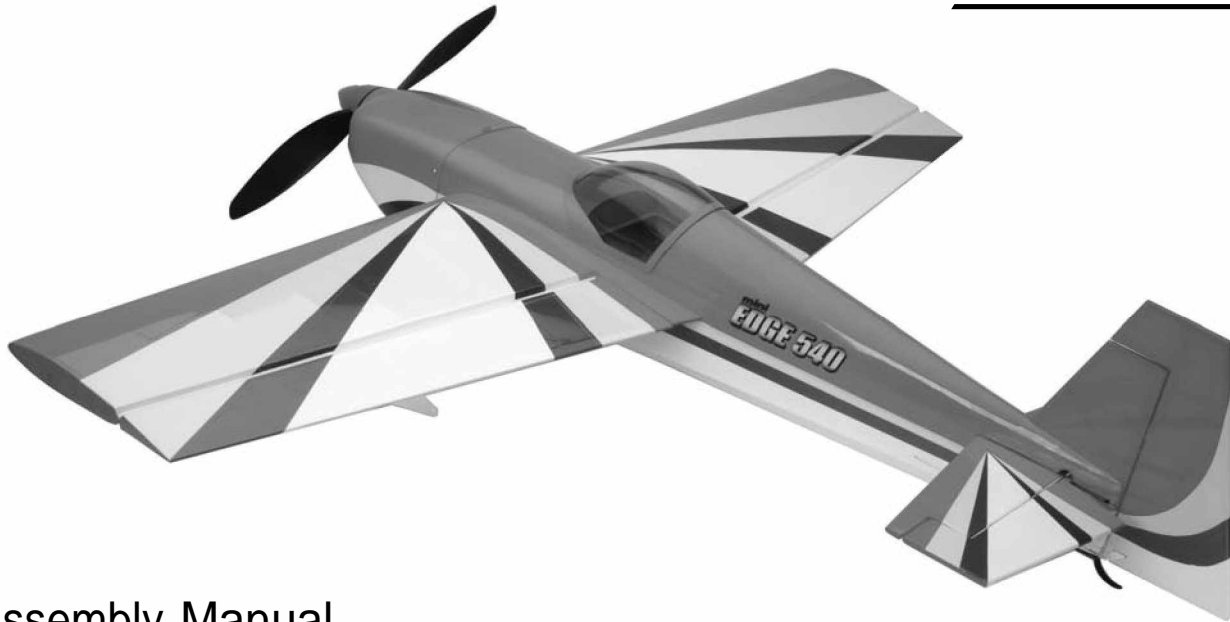

Assembly Manual

Available from: www.modelflight.com.au

Table of Contents

Introduction.....	2
Specifications.....	2
Contents of Kit/Parts Layout.....	3
Required Electronics & Accessories.....	4
Recommended High Performance Motor Setup*.....	4
Extreme High Performance Motor Setup*.....	5
Optional Accessories.....	5
Additional Tools and Adhesives.....	5
Important Information About Motor Selection.....	6
Using the Manual.....	6
Warning.....	6
Before Starting Assembly.....	6
Warranty Information.....	7
Landing Gear Installation.....	8
Aileron Hinging.....	12
Aileron Servos and Linkages.....	14
Wing Installation.....	18
Stabilizer and Elevator.....	19
Rudder and Fin.....	22
Motor Installation.....	25
Rudder and Elevator Servos.....	28
Receiver, Battery and ESC Install.....	34
Canopy Install.....	36
Cowling Install.....	38
Control Throws.....	40
Center of Gravity.....	41
Range Test Your Radio.....	41
2005 Official AMA National Model Aircraft Safety Code.....	42

Introduction

Thank you for purchasing the Mini Edge 540 3D ARF, which is based on the popular 33% Hangar 9® Edge 540 and is capable of the same extreme 3D performance you get with larger models. Backed by E-flite's high quality reputation, the Mini Edge 540 should provide you with the superior performance and features you are looking for in an aerobatic park flyer.

We provide a 6.6:1 gearbox and a 12 x 6 propeller so you can easily add our E-flite™ Park 400 Brushless motor for extreme performance. The Mini Edge features lightweight balsa and light-ply construction, UltraCote® covering, fiberglass cowl and wheel pants, and carbon fiber landing gear. The mid-wing design makes it ideal for aerobatics such as hovering and other precision 3D maneuvers.

Specifications

Wingspan: 37.25" (945 mm)

Length: 34" (860 mm)

Wing Area: 297 sq in (19 sq dm)

Weight w/o Battery: 20–21 oz (570–595 g)

Weight w/ Battery: 24–26 oz (680–740 g)

Contents of Kit/Parts Layout

Large Replacement Parts:

EFL2226	Wing Set with Ailerons
EFL2227	Fuselage with Hatch
EFL2228	Tail Set
EFL2230	Main Landing Gear
EFL2231	Fuse Hatch
EFL2232	Canopy
EFL2233	Painted Cowl
EFL2234	Painted Wheel Pants

Small Replacement Parts

EFL2086	Hook & Loop Tape
EFL2229	Pushrod Set
EFL2235	Wing Tube
EFL2236	Stick Motor Mount
EFLA200	Micro Control Horns
EFLA202	Micro Tail Skid
EFLA203	Micro Control Connectors
EFLA213	E-flite/JR/Horizon Decals
EFLA214	Micro Pull-Pull Set
EFLA216	Spinner
EFLA221	Foam Park Wheels, 1.5"
EFLM207	Pinion Gear, 10T 0.4 Module
EFLM221	Gearbox, 6.6:1
EFLM222	Spur Gear, 66T w/Shaft
EFLP1260	12 x 6 Slow Flyer Prop (includes only 1)

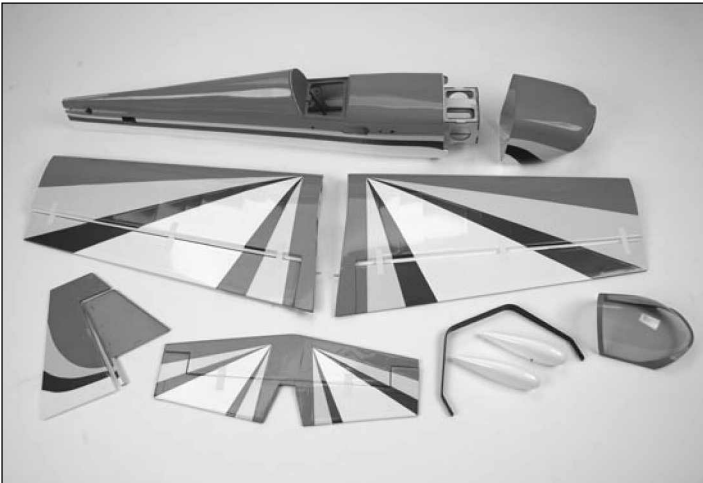

Required Electronics & Accessories

JRP6654**	6102FM, R610UL & 4-S241—Complete Radio System
JRPR610UL**	R610UL 6CH FM Receiver, Shrinkwrap
JRPS241	S241 Sub-Micro Servo (4)
JRPA212	Large Arms w/Screws (2)
JRPA095	6" Servo Extension (2)
JRPA098	12" Servo Extension
EFLA311B	20A Brushless ESC (version 2)
EFLC3005	Celectra 1–3 Cell Li-Po Charger
EFLA250	Park Flyer Tool Assortment, 5-pc

Recommended High Performance Motor Setup*

EFLM1105	Park 400 Brushless Motor, 3700Kv
EFLM1912	Heat Sink, 20mm x 20mm: Park 400
EFLP1260	12 x 6 Slow Flyer Prop (keep extras on hand)
EFLB1035	11.1V 2100mAh 3-Cell Li-Po, 16GA or
THP21003S	2100mAh 3-Cell 11.1V Li-Po, 16GA

* Use with included 12 x 6 prop, 6.6:1 gearbox, and 10T pinion. Proper throttle management is required when using high performance setups. Always monitor motor temperature and gearbox wear.

Extreme High Performance Motor Setup*

EFLM1100	Park 400 Brushless Motor, 4200Kv
EFLM1912	Heat Sink, 20mm x 20mm: Park 400
EFLP1260	12 x 6 Slow Flyer Prop (keep extras on hand)
EFLB1035	11.1V 2100mAh 3-Cell Li-Po, 16GA or
THP21003S	2100mAh 3-Cell 11.1V Li-Po, 16GA

* Use with included 12 x 6 prop, 6.6:1 gearbox, and 10T pinion. Proper throttle management is required when using high performance setups. Always monitor motor temperature and gearbox wear.

Optional Accessories

EFLA110	Power Meter
EFLA212	Gear Puller: 1–5mm Shaft
JRPS281	DS281 Micro Digital Servo (4)

Additional Tools and Adhesives

Tools & Equipment

Hobby knife	Square
Ruler	Felt-tipped pen
T-pins	Paper towel / tissue
Heat gun	
Wax paper	String
Tape	Pliers
Drill	Drill bit: 1/16" (2mm), 1/8" (3mm)
150–180 Grit sandpaper	
Hex wrench: 3/32"	(EFLA251 - included with EFLA250)
Nut driver: 5.5mm	(EFLA255 - included with EFLA250)
Small Phillips screwdriver	(EFLA257 - included with EFLA250)

Adhesives

Thin CA	Medium CA
Canopy glue	Threadlock
6-Minute Epoxy	- (HAN8000)

Important Information About Motor Selection

We are recommending either the E-flite™ Park 400 Brushless Motor with 4200Kv (EFLM1100) or the version with 3700Kv (EFLM1105). The 3700Kv motor provides plenty of power for sport and entry-level 3D pilots with the ability to hover and climb vertically using the stock 6.6:1 gearbox and 12 x 6 propeller. This motor will draw less current and provide longer flight duration. The 4200Kv motor should only be used by experienced pilots who manage throttle appropriately. This motor will provide even better vertical performance at the expense of flight duration due to the increased current draw. It is extremely important to monitor gearbox wear and motor temperature when using the 4200Kv motor. Lack of proper throttle management using this motor may result in damage to the motor, gearbox, ESC, and battery.

Using the Manual

This manual is divided into sections to help make assembly easier to understand, and to provide breaks between each major section.

Remember to take your time and follow the directions.

Warning

An RC aircraft is not a toy! If misused, it can cause serious bodily harm and damage to property. Fly only in open areas, preferably at AMA (Academy of Model Aeronautics) approved flying sites, following all instructions included with your radio.

Lithium Polymer batteries are significantly more volatile than alkaline or Ni-Cd/Ni-MH batteries used in RC applications. All manufacturer's instructions and warnings must be followed closely. Mishandling of Li-Po batteries can result in fire.

Before Starting Assembly

Before beginning the assembly of your Mini Edge, remove each part from its bag for inspection. Closely inspect the fuselage, wing panels, rudder and stabilizer for damage. If you find any damaged or missing parts, contact the place of purchase.

Warranty Information

Horizon Hobby, Inc. guarantees this kit to be free from defects in both material and workmanship at the date of purchase. This warranty does not cover any component parts damage by use or modification. In no case shall Horizon Hobby's liability exceed the original cost of the purchased kit. Further, Horizon Hobby reserves the right to change or modify this warranty without notice.

In that Horizon Hobby has no control over the final assembly or material used for the final assembly, no liability shall be assumed nor accepted for any damage resulting from the use of the final assembled product. By the act of using the assembled product, the user accepts all resulting liability.

Please note that once assembly of the model has been started, you must contact Horizon Hobby, Inc. directly regarding any warranty question. Please do not contact your local hobby shop regarding warranty issues, even if that is where you purchased it. This will enable Horizon to better answer your questions and service you in the event that you may need any assistance.

If the buyer is not prepared to accept the liability associated with the use of this product, the buyer is advised to return this kit immediately in new and unused condition to the place of purchase.

Horizon Hobby, Inc.
4105 Fieldstone Road
Champaign, Illinois 61822
877-504-0233
horizonhobby.com

Landing Gear Installation

Required Parts

Fuselage	Carbon main gear
Tail skid	Wheel pant (2)
1 1/2" (38mm) wheel (2)	2mm x 25mm screw (2)
2mm nut (4)	#4 washer (black) (2)
4-40 x 1/2" socket screw (2)	2mm washer (4)
2mm x 6mm wood screw (2)	

Required Tools and Adhesives

Threadlock	1/8" (3mm) drill bit
Drill	Medium CA
Hobby knife	Hex wrench: 3/32"
Phillips screwdriver (small)	

Note: You may consider using a larger diameter wheel, such as 2 1/4 in, if your flying site has rough terrain. By using a larger wheel, you will not be able to use the included wheel pants.

1. Slide the 2mm x 25mm screw through one of the wheels. Thread a 2mm nut onto the screw. Slide a 2mm washer onto the screw. This will all fit inside the wheel pant.

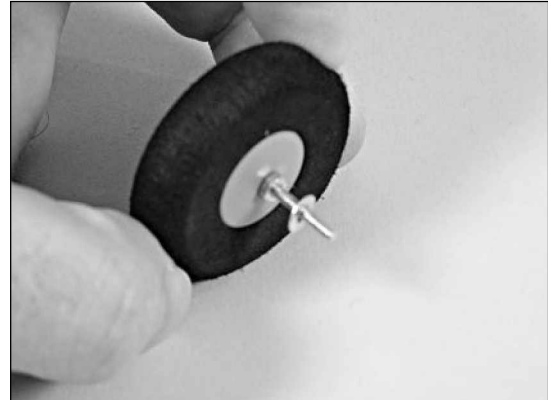

2. Fit the assembly from Step 1 into the wheel pant. Use a 2mm washer and nut to attach the wheel to the lower hole on the landing gear.

Note: Use threadlock on both nuts to prevent them from loosening during flight.

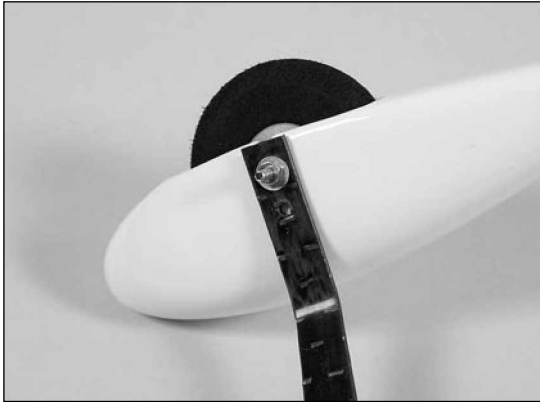

3. Repeat Steps 1 and 2 for the remaining wheel and pant.

4. Drill 1/8" (3mm) holes in the tail for the tail skid.

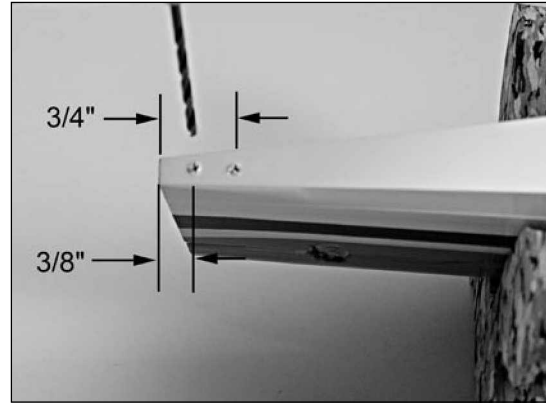

5. Glue the tail skid into position using Medium CA.

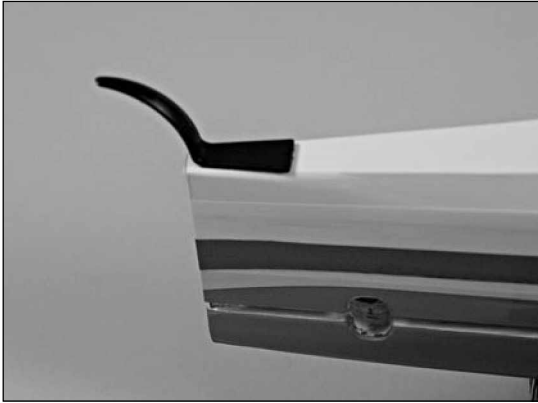

6. Attach the landing gear using a 3/32" hex wrench, two 4-40 x 1/2" socket head screws and two #4 washers (black).

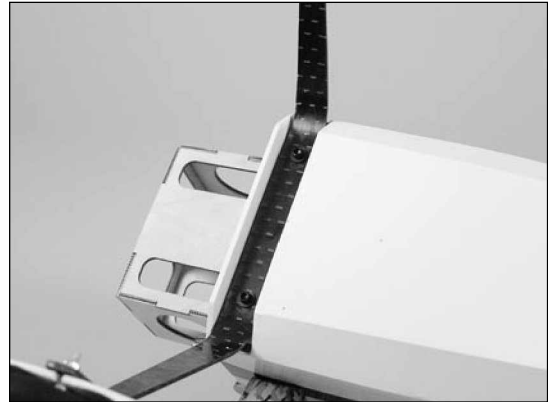

7. Place the fuselage on its wheels and position the wheel pants parallel to the work surface. Drill a hole through the landing gear into each wheel pant using a hobby knife.

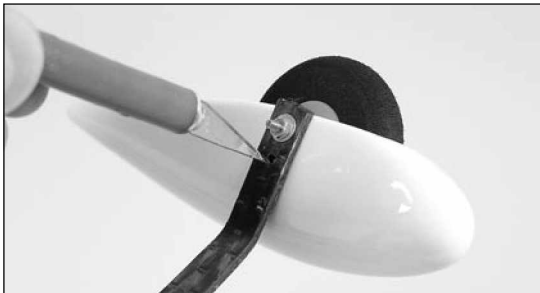

8. Secure the location of the wheel pants using 2mm x 6mm wood screws and a small Phillips screwdriver.



Aileron Hinging

Required Parts

Wing (left and right)	Aileron (left and right)
CA hinges (8)	

Required Tools and Adhesives

1/16" (2mm) drill bit	Drill
T-pins	Thin CA
Paper towel	

1. Locate the positions for the hinges. Drill a 1/16" (2mm) hole in the center of each slot of both the wing and aileron. This creates a tunnel for the CA, allowing the CA to penetrate into the hinge better, bonding the hinges more securely.

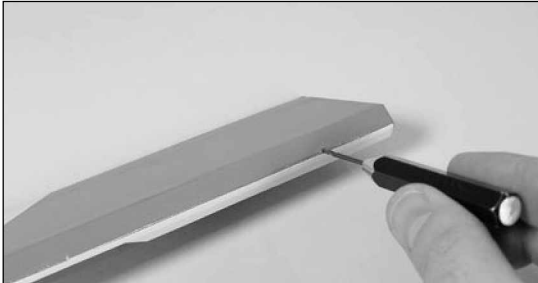

2. Slide four hinges into the slits in the aileron. Center the slot in the hinge with the hole drilled in Step 1. Place a T-pin in each hinge to prevent it from being pushed into the wing when installing the aileron.

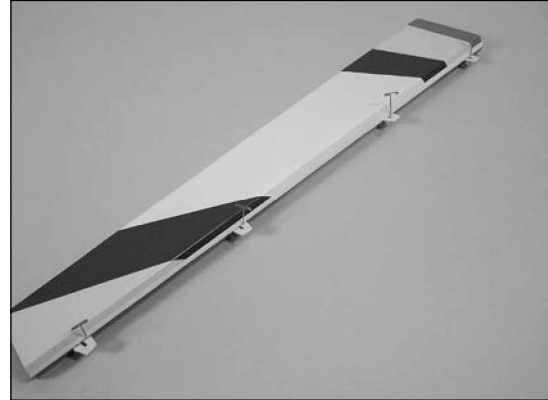

Note: Do not use CA accelerator during the hinging process. The CA must be allowed to soak into the hinge to provide the best bond. Using accelerator will not provide enough time for this process.

3. Slide the aileron into position. Check to make sure it can move without interference at the wing root. Remove the T-pins and apply Thin CA to each hinge. Make sure the hinge is fully saturated with CA. Use a paper towel to clean up any excess CA from the wing and aileron. Make sure to apply CA to both sides of the hinge.

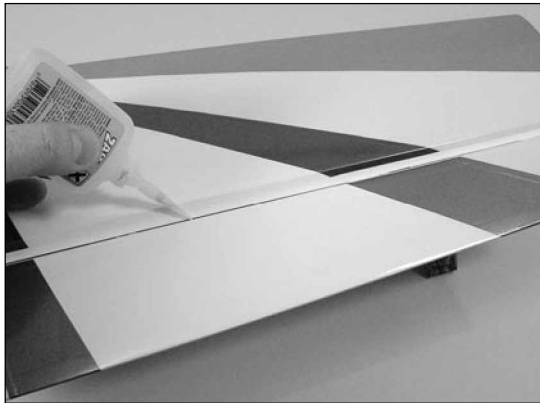

4. Firmly grasp the wing and aileron and gently pull on the aileron to ensure the hinges are secure and cannot be pulled apart. Use caution when gripping the wing and aileron to avoid crushing the structure.

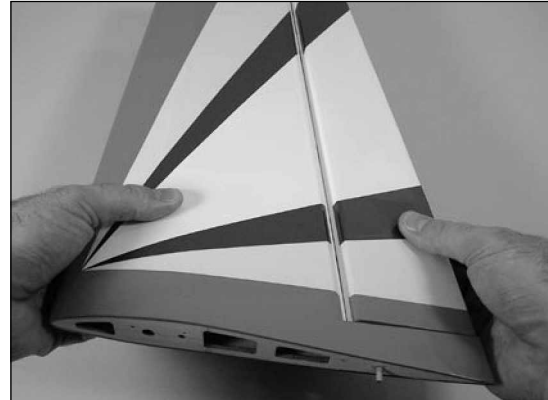

5. Work the aileron up and down several times to work in the hinges and check for proper movement.

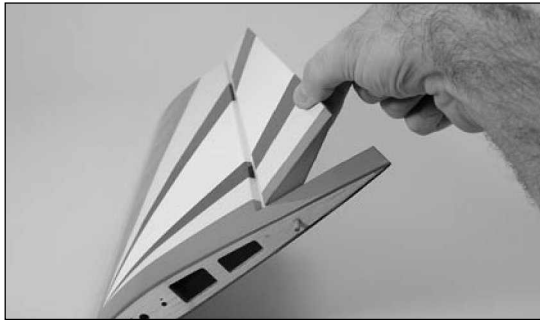
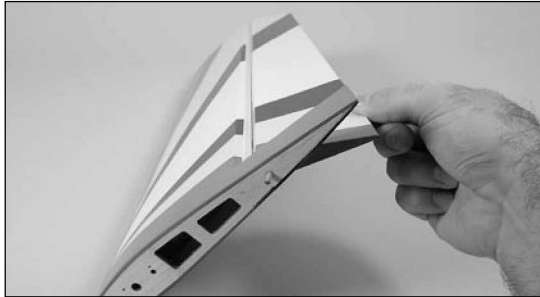

6. Repeat Steps 1 through 5 for the remaining aileron.

Aileron Servos and Linkages

Required Parts

Wing panel (right and left)
Micro control connector (2)
2mm x 4mm screw (2)
3 ³/₈" (85 mm) pushrod (2)
Control horn and backplate (2)
Servos: JR 241 Sub-micro servo (JRPS241) (2)
Large Arm w/Screws (JRPA212) (2)

Required Tools and Adhesives

Hobby knife
6-minute epoxy
6" (150mm) servo extension (2) String
Phillips screwdriver (small)

1. Install the grommets and brass eyelets on the servo using instructions provided with the radio system. Attach a 6" (150mm) servo extension. Use string to secure the servo lead and extension to prevent them from unplugging in flight.

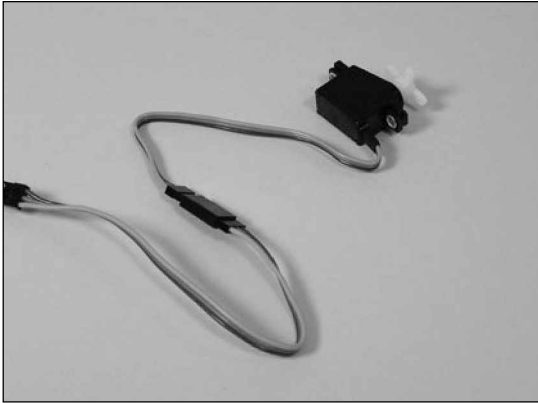

Note: We suggest using the Large Arms w/Screws (JRPA212) on all JR® servos for the Mini Edge. Replace all existing arms before installing the servos.

2. Place the servo in the wing. Guide the servo lead out through the opening at the wing root.

3. Secure the aileron servo using the screws provided with the servo.

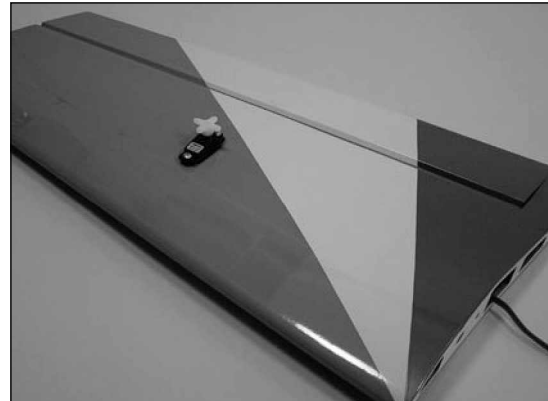

4. Use a hobby knife to enlarge the center hole in the control horn to fit the $3\frac{3}{8}$ " (85 mm) long aileron pushrod wire.

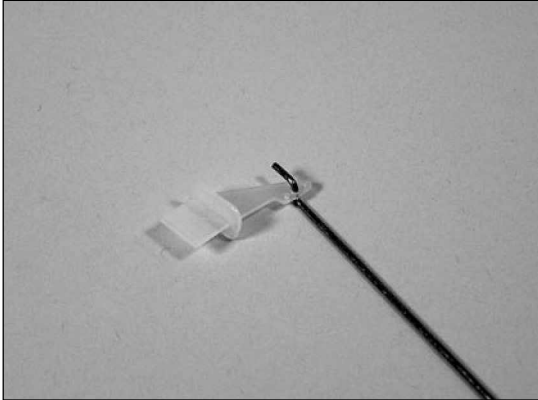

5. Use 6-minute epoxy to attach the control horn to the aileron.



6. Attach the micro control connector to the servo arms. Be sure to use the included retainer to secure the micro control connector to the servo arm.

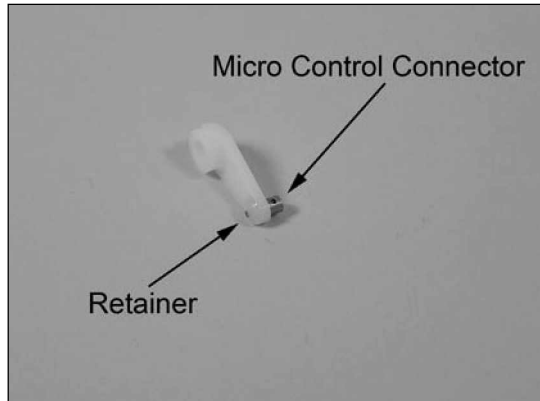

7. Turn on the radio system and center the aileron trim and stick. Make sure the aileron servo is operating properly using the transmitter. Slide the pushrod wire through the micro connector. Install the servo arm 90-degrees to the servo. Center the aileron, and secure the position of the wire using the 2mm x 4mm screw and a Phillips screwdriver.

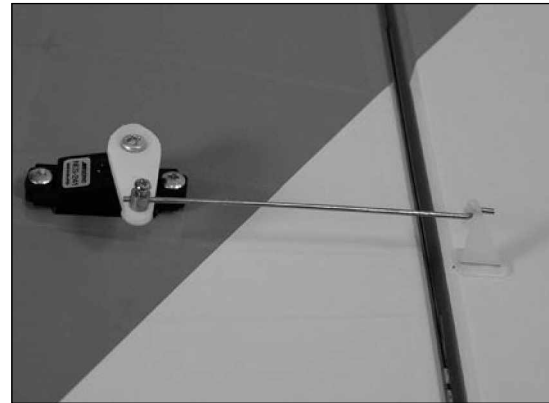

8. Repeat Steps 1 through 7 for the other wing panel.

Wing Installation

Required Parts

Fuselage	Wing (right and left)
Wing tube	#4 washer (silver) (2)
4-40 x 1/2" socket head screw (2)	
Hex wrench: 3/32"	

1. Slide the wing tube into a wing panel.
2. Remove the hatch from the fuselage. Slide the wing panel with tube into position on the fuselage.



3. Slide the remaining wing panel into position. Secure the panels using 4-40 x 1/2" socket head screws with #4 washers (silver) using a 3/32" hex wrench.

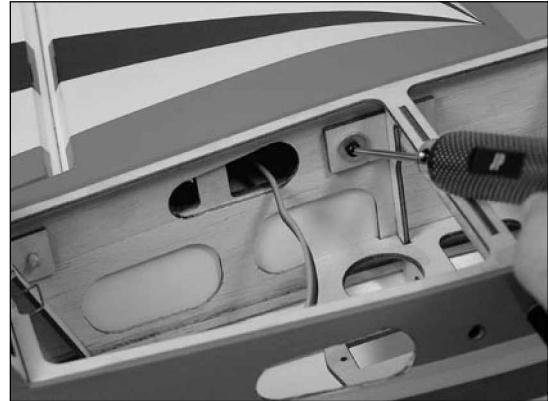

Stabilizer and Elevator

Required Parts

Fuselage w/wing installed	Stabilizer
Elevator	CA hinge (4)
Filler plug	

Required Tools and Adhesives

Hobby knife	Felt-tipped pen
Ruler	T-pins
Thin CA	

1. Position the stabilizer into the slot in the aft end of the fuselage. Center the stabilizer in the slot in the fuselage.

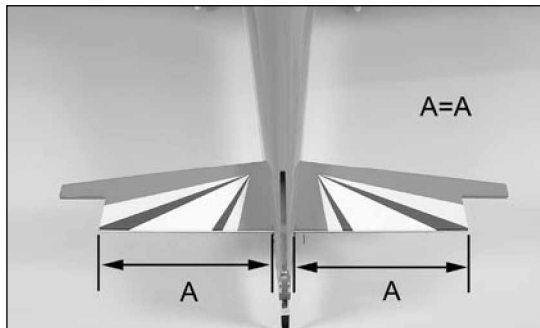

2. Measure from the stab tip to the wing tip. Adjust the stab until the measurements are equal.

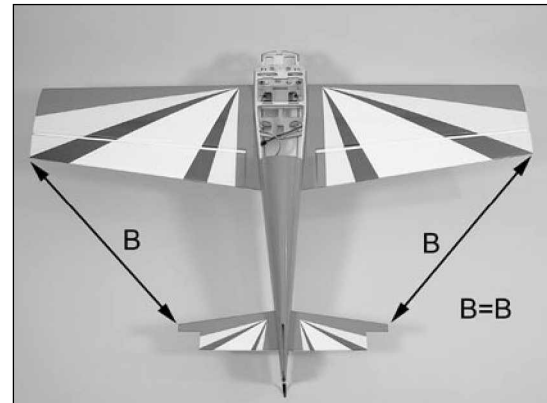

3. View the airframe from the rear and make sure the wing and stab are parallel. If not, lightly sand the stab saddle until they are.

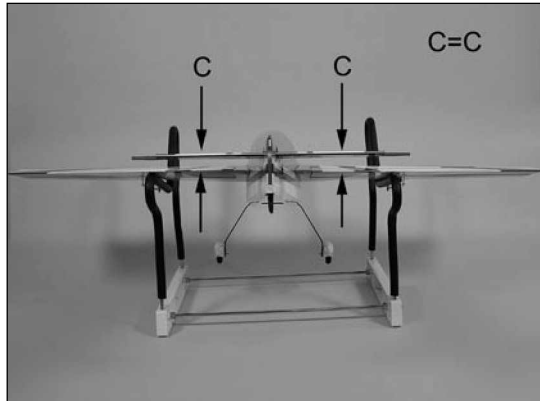

4. Double-check the adjustments from Steps 1 through 3. Use a felt-tipped pen to trace the outline of the fuselage onto the top and bottom of the stabilizer.



5. Use a sharp hobby knife to cut the covering slightly inside the lines drawn. Be very careful not to cut into the underlying wood, as this will weaken the stab and cause it to fail in flight.

Note: You can use a soldering iron instead of a knife. This will eliminate the chance of cutting into the wood.

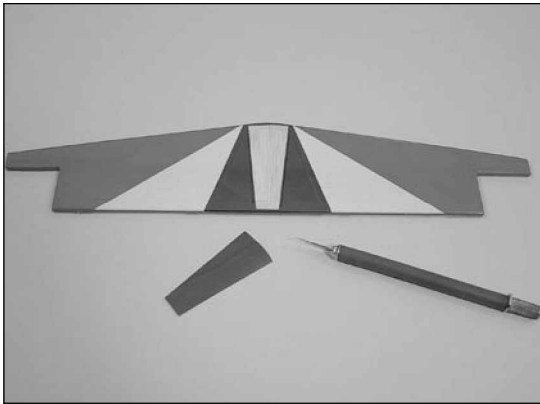

6. Hinge the elevator and stabilizer, using the same process as described in Aileron Hinging. Use 4 hinges for this process.

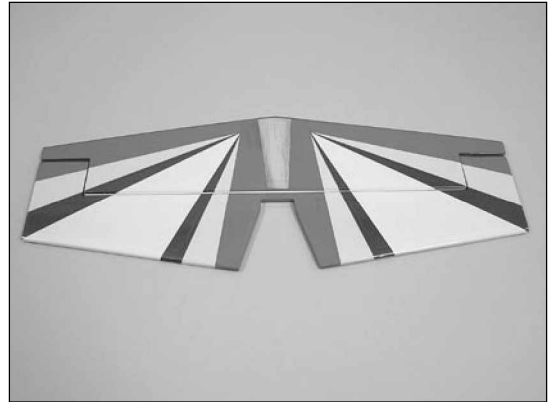

7. Slide the stab and elevator back into position. Again, check the alignment and make sure everything lines up. Wick Thin CA into the joint between the fuselage and stabilizer. Make sure to glue both top and bottom. Do not use accelerator—allow the CA to wick in as far as possible, providing the best bond. Place the filler plug in place behind the elevator, but do not glue at this time.

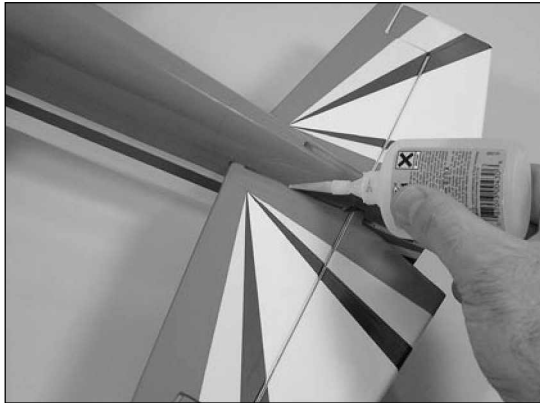

Rudder and Fin

Required Parts

Fuselage	Rudder
Fin	CA hinge (3)

Required Tools and Adhesives

Hobby knife	Thin CA
Felt-tipped pen	Square

1. Place the fin in position on the fuselage. Trace the outline of the fuselage onto both sides of the fin.

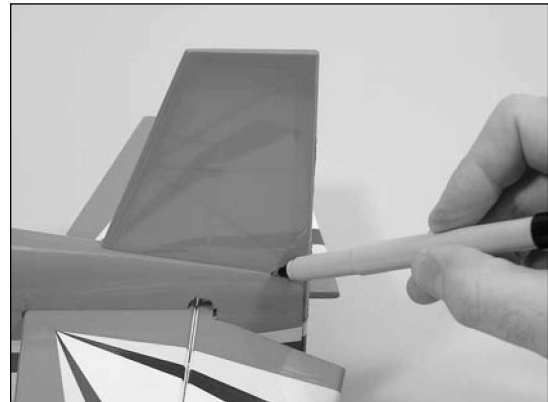

2. Remove the covering from the bottom of the fin using the same technique used for the stabilizer.

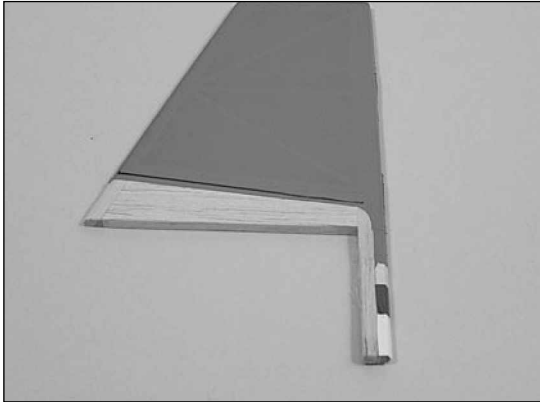

3. Position the fin back onto the fuselage. Use a square to check the alignment between the fin and stabilizer. Lightly sand the bottom of the fin until the alignment is correct.

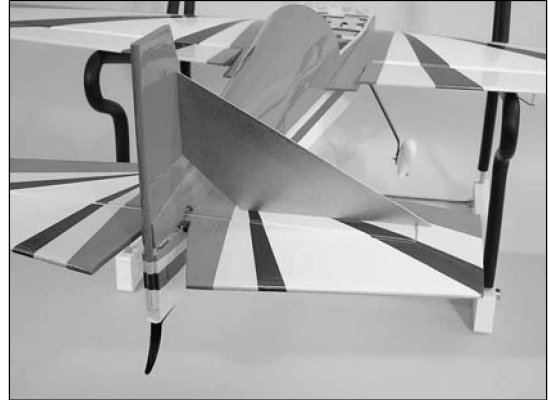

4. Use thin CA to glue the fin to the fuselage.



5. Attach the rudder using three CA hinges. Use the technique as described in Aileron Hinging for this procedure. Use thin Ca to glue the filler plug at the rear of the fuselage.

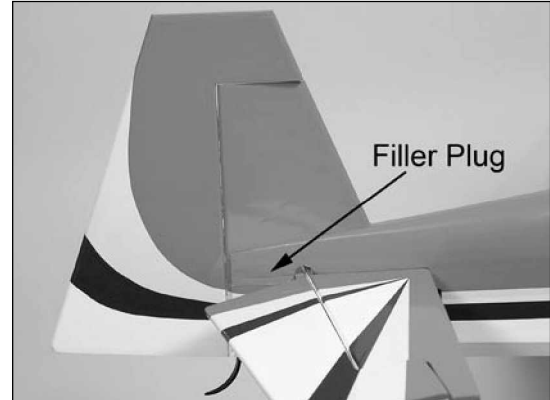

Motor Installation

Required Parts

Fuselage	6.6:1 gearbox
Motor support stick	Brushless motor
2mm x 8mm sheet metal screw	

Pinion gear, 10T 0.4 module

Required Tools and Adhesives

6-minute epoxy	Hobby knife
150–200 grit sandpaper	

1. It may be necessary to attach motor adapters or other accessories to your particular motor at this time. Use the instructions provided with your motor to install any accessories.

Use the 10T pinion gear included with this airplane on your motor if you are using our included 6.6:1 gearbox.

Note: When installing your motor into the E-flite™ gearbox, it is very important that your gear mesh is set correctly and the gear's mesh is smooth with no binding. The E-flite gearbox features adjustable slotted mounting holes so that you can ensure your gear mesh is correct. Remember, if your mesh is too loose or too tight, it may strip the gears. See the instructions included with your E-flite gearbox for more helpful tips on gear mesh and motor installation.

Proper gear mesh is extremely important for high power setups, such as those systems typically used to power the Mini Edge. Be certain to check the mesh at multiple points on the spur gear before finalizing the motor mounting position in the gearbox. To extend the life of your gearbox, we also recommend using a small amount of grease, such as lithium grease, on the spur gear.

We strongly recommend the use of our E-flite Park 400 Brushless Motor. All product testing was conducted with this motor.

2. Attach the motor to the gearbox using screws provided with the motor. Follow the instructions provided with the gearbox for some helpful installation hints.



3. Locate the motor support stick. Position the stick so it extends $2\frac{1}{8}$ " forward of the firewall as shown. Use 6-minute epoxy to glue the support to the two formers at the front of the fuselage and to the plate on the top of the motor box.

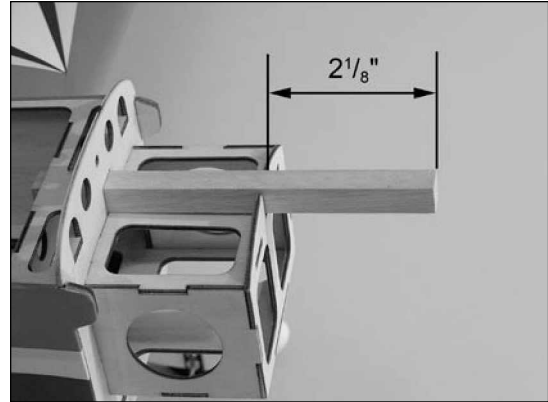

- Slide the gearbox into position on the motor support stick. Use a hobby knife to make a hole in the gearbox and into the motor stick. Secure the gearbox to the motor stick using a 2mm x 8mm sheet metal screw.



Rudder and Elevator Servos

Required Parts

Fuselage	Plastic rudder horn
2mm x 4mm screw (3)	Pull-pull cable
3" (75 mm) pushrod wire	Brass cable keepers (4)
Micro control horn w/backplate	
Micro control connector w/retainer (3)	
Servos: JR 241 Sub-micro Servo (JRPS241) (2)	
12" (305 mm) servo extension	

Micro cable adjust connector (2)

Required Tools and Adhesives

Phillips screwdriver (small)	Hobby knife
Medium CA	Thin CA

1. Install the grommets and brass eyelets in the elevator servo. Secure a 12" (305 mm) servo extension to the servo. Mount the elevator servo using the hardware provided with the servo.

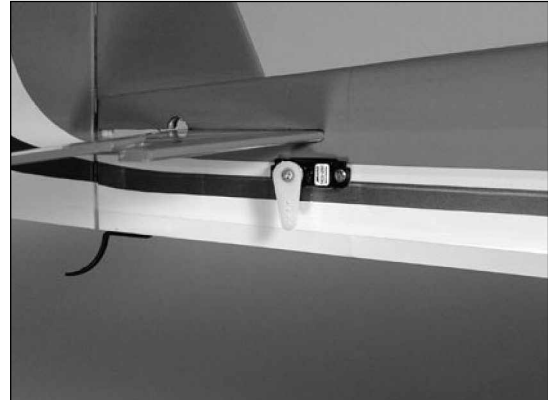

2. Use a hobby knife to enlarge the center hole in one of the remaining control horns. Attach the 3" (75mm) pushrod wire to the control horn.

3. Attach the micro control horn to the elevator using the control horn backplate and 6-minute epoxy.

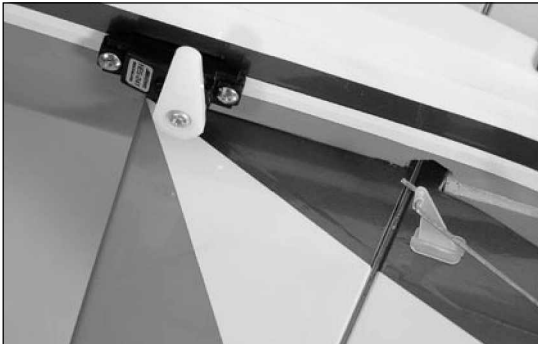

4. Install the micro control connector onto the elevator servo arm. Pass the elevator pushrod wire through the connector. With the radio on and elevator trim centered, center the elevator. Secure the elevator pushrod wire using the 2mm x 4mm screw and a small Phillips screwdriver.



Note: An optional rudder servo location has been provided at the rear of the fuselage if using heavier motors and you choose not to use the pull-pull system. The installation procedure is identical to the elevator servo installation, except the covering must be removed from the fuselage first.

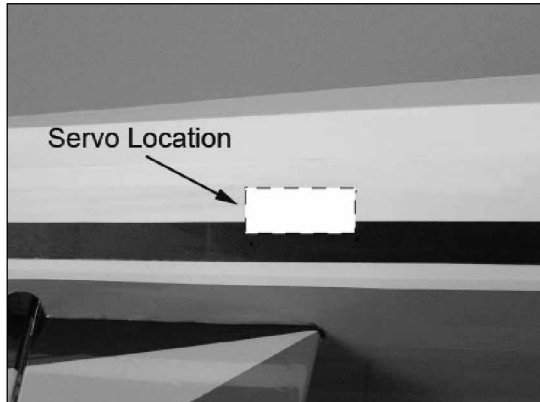

Note: Steps 6 through 13 illustrate the installation of the pull-pull system. When using the pull-pull system continue on starting at Step 6.

5. Lightly sand both sides of the middle section of the plastic rudder control horn before installing so the CA wicks better. Install the rudder control horn for the rudder using medium CA. Square the horn to the control surface.



6. Install the grommets and brass eyelets in the rudder servo. Mount the rudder servo using the hardware provided with the servo.

7. Install two micro control connectors into a long servo arm. Secure them using the control connector back plates.
8. With the radio system on, install the servo arm on the rudder servo.

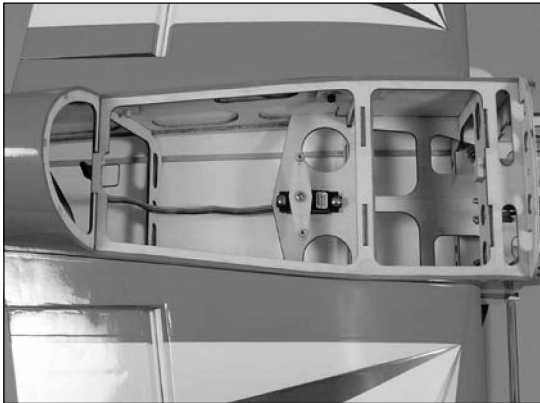

9. Use tape to hold the rudder in neutral. Slide a cable crimp onto the control cable. The cable then goes through the horn, then back through the crimp twice. Pull the wire tight, then use pliers to secure the crimp. Add a small drop of thin CA inside the brass crimp to help secure the wire. Wipe away any excess immediately.

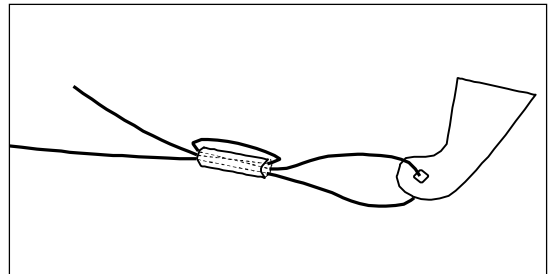

10. Use a hobby knife to remove the covering from the openings where the cable will enter the fuselage. You can see the exit holes through the covering by holding the plane up to a light.

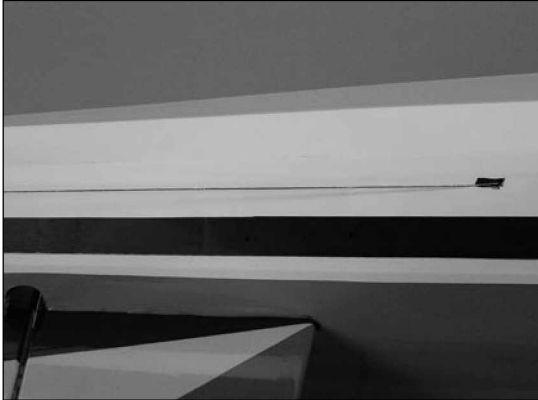

11. Slide the micro cable adjust connector into the micro control connector and use a 2mm x 3mm screw to hold it in position. Repeat Step 9, installing the cable through the cable connector.

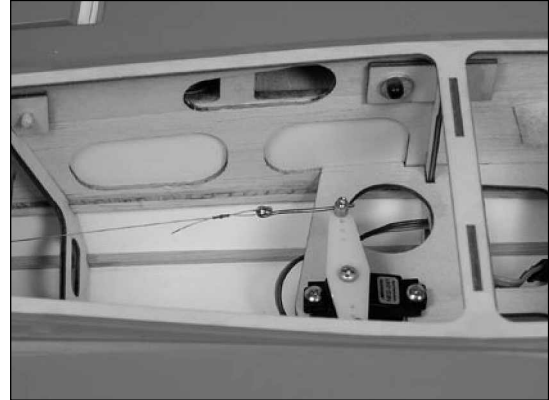

12. The cables will cross inside the fuselage to get the proper geometry for the rudder to operate correctly.

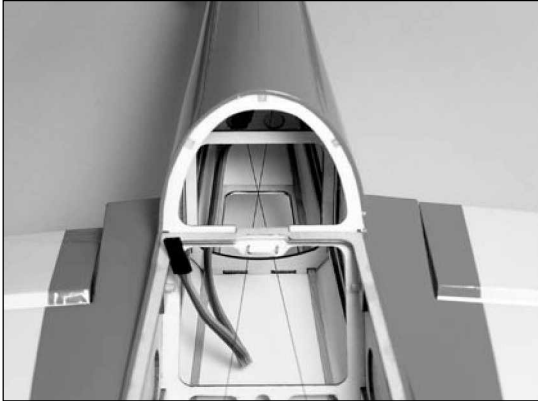

13. Remove the tape from the control surface. Install the second cable following Steps 9 through 11. Tension the cables lightly using the cable connectors to pull the surface into neutral.

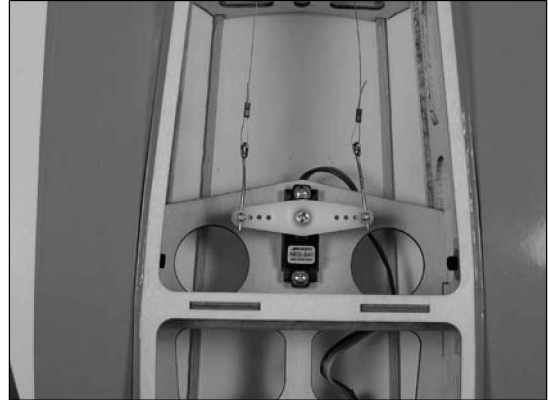

Receiver, Battery and ESC Install

Required Parts

Fuselage	Battery
Hook and loop tape (2)	Receiver
Brushless speed control	

Required Tools and Adhesives

Thin CA

Optional Parts

Hook and loop strap

Important Information about Your Brushless ESC

Make sure your ESC brake is programmed to 'off'. Also, be sure to use an ESC with the proper 9V cutoff when using 3-Cell Li-Po packs. We suggest this cutoff to be of the soft variety to prevent hard motor cutoffs during low level 3D flying.

Most 20A–25A brushless esc on the market either warn against running four (4) sub-micro servos or do not specify this setup will work. The reason is because often times running four sub-micro servos with a 3-cell Li-Po battery are outside the range of the controller's BEC capability. Most controllers on the market can only handle 800mA to 1 Amp continuous when using a 3-cell Li-Po battery, some even lower. However, many consumers are still running four sub-micro servos with success.

If you choose to attempt this you must setup your plane properly and check the current draw (under load) of your radio system making sure it is within the specifications of the controller's BEC. Be sure to put the esc in a position to get the best airflow since cooling will help the BEC capacity.

We now have a new version of the E-flite 20A Brushless ESC (EFLA311B) which is equipped with a higher rated, heavy-duty BEC that can dissipate more heat and handle higher wattage when using a 3-cell Li-Po battery. Make sure you specify this new part number to ensure you are getting the updated controller. You should always still check your setup first before flying.

Some other alternatives are available:

1. Disable the controller's BEC per manufacturer's instructions and use a flight pack battery.
2. Buy a device such as an external BEC that is specified to handle more current.
3. Select a controller such as the Castle Phoenix 35 or our updated E-flite 20A Brushless ESC (EFLA311B) that has a higher rated, heavy-duty BEC.

1. Check to make sure all servo wires and ESC wires can reach the location of the receiver before mounting the receiver. Cut a piece of the hook and loop tape to the size of the receiver. Install the receiver using the hook and loop. Plug in the rudder, elevator, and aileron servos. Route the receiver antenna to the rear of the plane.



Note: Do not cut the receiver antenna, as this will greatly reduce the range of the radio system.

Hint: Position the receiver so the ailerons can be plugged in easily.

2. Use hook and loop material to mount the electronic speed control. Attach the ESC to the inside of the fuselage to provide room for the motor battery.

2. Position the canopy. Trace the outline of the canopy onto the canopy hatch using a felt-tipped pen.

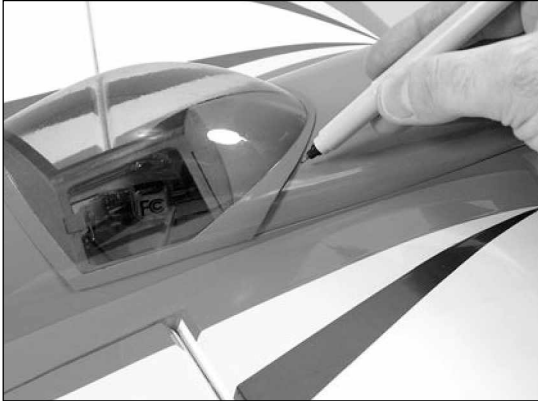

3. Lightly sand the inside edge of the canopy where it contacts the hatch. Also sand the hatch inside the line drawn in the last step.



4. Glue the canopy to the hatch using canopy glue. Tape the canopy into position until the glue cures.



Cowling Install

Required Parts

Fuselage	Cowling
12x6 propeller	Spinner
3mm locknut	3mm washer
2mm x 8mm wood screw (4)	

Required Tools and Adhesives

Hobby knife
Phillips screwdriver (small)

1. Slide the cowl onto the fuselage. Center the motor shaft in the opening.

2. Attach the propeller and spinner using the supplied 3mm washer and 3mm locknut. Make sure not to over-tighten the 3mm locknut.



Note: It is very important that you check to be sure the propeller is balanced before installing onto the shaft. An unbalanced propeller may strip the gear. When installing the propeller, please do not over-tighten the 3mm locknut. The use of the locknut will prevent the propeller from coming loose.

3. Check to make sure the propeller and spinner will not interfere with the front of the cowl and there is adequate clearance. Use a hobby knife to make holes in the cowl at the same location as the tabs on the fuselage. Secure the cowl to the fuselage using the 2mm x 8mm wood screws and a Phillips screwdriver.



Control Throws

1. Turn on the transmitter and receiver of your Mini Edge. Check the movement of the rudder using the transmitter. When the stick is moved right, the rudder should also move right. Reverse the direction of the servo at the transmitter if necessary.
2. Check the movement of the elevator with the radio system. Moving the elevator stick down will make the airplane elevator move up.
3. Use a ruler to adjust the throw of the elevator, ailerons and rudder. Adjust the position of the pushrod at the control horn to achieve the following measurements when moving the sticks to their endpoints.

Ailerons:

Low rate	3/4" (19mm) Up/Down
High Rate	2" (51mm) Up/Down

Elevator:

Low Rate	1/2" (13mm) Up/Down
High Rate	1 5/8" (41mm) Up/Down

Rudder:

Low Rate	1 1/2" (38mm) Left/Right
High Rate	3" (76mm) Left/Right

These are general guidelines measured from our own flight tests. You can experiment with higher rates to match your preferred style of 3D flying.

Center of Gravity

An important part of preparing the aircraft for flight is properly balancing the model.

Caution: Do not inadvertently skip this step!

The recommended Center of Gravity (CG) location for the Mini Edge is $2\frac{1}{8}$ " (54mm) to $2\frac{7}{16}$ " (62mm) behind the leading edge of the wing against the fuselage. Use this C.G. range for the first flights until you have become more experienced.

The C.G. range was determined from our flight tests. The forward range is better suited for sport and precision aerobatics, while the aft (rear) location is for more wild and 3D flying. You can experiment with the best locations to suit your flying style.

Range Test Your Radio

1. Before each flying session, be sure to range check your radio. This is accomplished by turning on your transmitter with the antenna collapsed. Turn on the receiver in your airplane. With your airplane on the ground and the engine running, you should be able to walk 30 paces (approximately 100 feet) away from your airplane and still have complete control of all functions. If not, don't attempt to fly! Have your radio equipment checked out by the manufacturer.
2. Double-check that all controls (aileron, elevator, rudder and throttle) move in the correct direction.
3. Be sure that your transmitter batteries are fully charged, per the instructions included with your radio.

2005 Official AMA National Model Aircraft Safety Code

GENERAL

- 1) I will not fly my model aircraft in sanctioned events, air shows or model flying demonstrations until it has been proven to be airworthy by having been previously, successfully flight tested.
- 2) I will not fly my model higher than approximately 400 feet within 3 miles of an airport without notifying the airport operator. I will give right-of-way and avoid flying in the proximity of full-scale aircraft. Where necessary, an observer shall be utilized to supervise flying to avoid having models fly in the proximity of full-scale aircraft.
- 3) Where established, I will abide by the safety rules for the flying site I use, and I will not willfully or deliberately fly my models in a careless, reckless and/or dangerous manner.
- 4) The maximum takeoff weight of a model is 55 pounds, except models flown under Experimental Aircraft rules.

5) I will not fly my model unless it is identified with my name and address or AMA number on or in the model. (This does not apply to models while being flown indoors.)

6) I will not operate models with metal-bladed propellers or with gaseous boosts, in which gases other than air enter their internal combustion engine(s); nor will I operate models with extremely hazardous fuels such as those containing tetranitromethane or hydrazine.

RADIO CONTROL

- 1) I will have completed a successful radio equipment ground range check before the first flight of a new or repaired model.
- 2) I will not fly my model aircraft in the presence of spectators until I become a qualified flier, unless assisted by an experienced helper.

3) At all flying sites a straight or curved line(s) must be established in front of which all flying takes place with the other side for spectators. Only personnel involved with flying the aircraft are allowed at or in front of the flight line. Intentional flying behind the flight line is prohibited.

4) I will operate my model using only radio control frequencies currently allowed by the Federal Communications Commission. (Only properly licensed Amateurs are authorized to operate equipment on Amateur Band frequencies.)

5) Flying sites separated by three miles or more are considered safe from site-to site interference, even when both sites use the same frequencies. Any circumstances under three miles separation require a frequency management arrangement, which may be either an allocation of specific frequencies for each site or testing to determine that freedom from interference exists. Allocation plans or interference test reports shall be signed by the parties involved and provided to AMA Headquarters. Documents of agreement and reports may exist between (1) two or more AMA Chartered Clubs, (2) AMA clubs and individual AMA members not associated with AMA Clubs, or (3) two or more individual AMA members.

6) For Combat, distance between combat engagement line and spectator line will be 500 feet per cubic inch of engine displacement. (Example: .40 engine = 200 feet.); electric motors will be based on equivalent combustion engine size. Additional safety requirements will be per the RC Combat section of the current Competition Regulations.

7) At air shows or model flying demonstrations, a single straight line must be established, one side of which is for flying, with the other side for spectators.

8) With the exception of events flown under AMA Competition rules, after launch, except for pilots or helpers being used, no powered model may be flown closer than 25 feet to any person.

9) Under no circumstances may a pilot or other person touch a powered model in flight.

E-fliteTM

HORIZON
H O B B Y

© 2005 Horizon Hobby, Inc.
4105 Fieldstone Road
Champaign, Illinois 61822
(877) 504-0233
horizonhobby.com
e-fliterc.com

7711

Available from: www.modelflight.com.au