

Eratic 3D 25e

Assembly Manual



Specifications

Wingspan:	54 in (1370 mm)
Fuselage Length:	53 in (1350 mm)
Wing Area:	695 sq in (44.9 sq dm)
Weight of Model w/o Battery:	3–3.25 lb (1.4–1.5 kg)
Weight of Model with Battery:	3.75–4 lb (1.7–1.8 kg)
Radio:	6 channels w/4 servos

E-flite[®]
ADVANCING ELECTRIC FLIGHT

Available from: www.modelflight.com.au

Table of Contents

Specifications.....	1
Introduction	2
Using the Manual.....	2
Trim Scheme	2
Contents of Kit/Parts Layout.....	3
Required Tools and Adhesives	3
Required Radio Equipment.....	4
Notes Regarding Servos and ESC	4
Important Information About Motor Selection	4
Lightweight Sport Setup	4
Optional Accessories.....	4
Recommended High Power Precision Aerobatic Setup.....	5
Alternative Sport and Precision Setups.....	5
Optional Accessories.....	5
Notes on Lithium Polymer Batteries	5
Warning.....	5
Warranty Period	5
Limited Warranty	6
Damage Limits	6
Safety Precautions	6
Questions, Assistance, and Repairs	7
Inspection or Repairs	7
Warranty Inspection and Repairs	7
Non-Warranty Repairs	7
Safety, Precautions, and Warnings	8
Instructions for Disposal of WEEE by Users in the European Union.....	8
Landing Gear Installation.....	9
Motor Installation	11
Aileron Installation	14
Wing Installation.....	19
Stabilizer and Elevator	20
Rudder and Fin	24
Rudder and Elevator Servos.....	25
Control Throws.....	27
Center of Gravity	28
Range Test Your Radio	29
Preflight.....	29
Flying Your Eratix 3D 25e.....	30
2007 Official AMA National Model Aircraft Safety Code.....	31

Introduction

The E-flite Eratix 3D 25e ARF is a 3D-capable sport plane designed to make the transition from sport models to more challenging 3D aircraft a lot less demanding. Its large wing area and light wing loading offer very forgiving flight characteristics, especially in slow flight. It's also compatible with a range of motor and propeller sizes so you can fine tune the power and performance to your skill level. Both the E-flite Power 25 and Power 32 brushless outrunner motors bolt to the firewall without any modifications. Experienced 3D pilots will appreciate the uniquely designed, machined aluminum 3D control arms that can handle the rigors of high-torque mini servos and large control throws. Sport aerobatics or stick-bending 3D, the Eratix 3D 25e is up for whatever you are.

Using the Manual

This manual is divided into sections to help make assembly easier to understand, and to provide breaks between each major section. In addition, check boxes have been placed next to each step to keep track of each step completed. Steps with a single circle () are performed once, while steps with two circles () indicate that the step will require repeating, such as for a right or left wing panel, two servos, etc.

Remember to take your time and follow the directions.

Trim Scheme

HANU896	Fluorescent Blue
HANU895	Fluorescent Orange
HANU964	Clear
HANU973	Lite White

Contents of Kit/Parts Layout

Large Replacement Parts:

EFL4076	Wing Set w/Ailerons
EFL4077	Fuselage
EFL4078	Tail Set
EFL4080	Main Landing Gear
EFL4083	Fuse Hatch
EFL4085	Canopy
EFL4079	Cowling
EFL4081	Wheel Pants
EFL4084	Wing Tube

Small Replacement Parts

HAN305	Pro-Lite Wheels, 2 3/4-inch (70mm)
EFL4082	Pushrod Set
EFLA213	E-flite/JR/Horizon Decals



Required Tools and Adhesives

Tools & Equipment

EFLA258	Screwdriver, #1 Phillips
EFLA257	Screwdriver, #0 Phillips (Both included with EFLA250)
EFLA251	Hex Wrench: 3/32-inch (or included with EFLA250)
EFLA263	Nut Driver, 1/4-inch
Drill	
Pen drill	
Drill bit: 1/16-inch (1.5mm), 5/64-inch (2mm)	
Masking tape	
Felt-tipped pen	
Hex wrench: 1.5mm	
Needle-nose pliers	
Medium grit sandpaper	
Side cutters	
T-pins	
Paper towels	
Hobby knife	
Ruler	
Square	
String or dental floss	
Pliers	
7mm nut driver	
Rotary tool	
Adhesives	
30-minute epoxy	
Thin CA	
Threadlock	

Required Radio Equipment

You will need a minimum 6-channel transmitter, receiver, and four mini servos. You can choose to purchase a complete radio system that includes all of these items or, if you are using an existing transmitter, just purchase the other required equipment separately.

Note: We recommend the crystal-free, interference-free Spektrum™ DX7 2.4GHz DSM2™ 7-channel radio. The complete system includes standard servos, which are not required for the Eratix 3D 25e.

Purchase Separately

SPM6070 DSM2 7-Channel Receiver

Or

JRPR720 7-Channel ScanSelect™ FM Receiver

Or

JRPR790 7-Channel ScanSelect PCM Receiver
JSP98030 12-inch (305mm) Servo Extension (2)
JRPSDS3421 DS3421 Digital MG Mini Servo (4)
HRC32225S HiTec 225MG

Note: When using our recommended E-flite 60A Pro Brushless ESC with switching BEC you do not need a separate receiver pack as long as you are using our recommended servos.

Important Servo Note:

If you plan on flying your Eratix 3D 25e to its full capabilities, we recommend only metal geared servos.

During 3D flight, the large control surfaces will exhibit large flight loads on the servos. Plastic geared servos failed during testing and are not recommended for use.

JSP98010
EXRA050

JR SPORT™ 4.8V 700mAh Rx Pack
Expert Standard Switch

Notes Regarding Servos and ESC

WARNING: Depending on what speed control you are using, if it is not capable of supporting four mini-size servos because of current draw, the speed control may shut down due to high heat.

Use of servos other than those we recommend may overload the BEC of the recommended Electronic Speed Control (ESC). We suggest the use of only the servos we recommend when utilizing the recommended ESC's BEC, or the use of a separate BEC (like the UBEC) or receiver battery pack when using other servos.

Important Information About Motor Selection

The Eratix 3D 25e does not include a propeller. We are recommending the Power 25 or Power 32 outrunner motors. The motor systems listed will provide you with excellent aerobatic power for sport and/or artistic aerobatic pilots.

Lightweight Sport Setup

EFLM4025A	Power 25 BL Outrunner, 870Kv
EFLA1060	60A Pro Switching BEC Brushless ESC
THP42003S2PPL	4200mAh 3S2P 11.1V Li-Po, 13GA
APC14070E	Electric Propeller, 14x7E
EFLC3005	Celectra™ 1- to 3-cell Li-Po Charger
EFLAEC303	EC3 Dev & Batt, Male/Female

This is a very good 3D/Aerobatic setup with strong performance.

Recommended High Power Precision Aerobatic Setup

EFLM4032A	Power 32 BL Outrunner, 770Kv
EFLA1060	60A Pro Switching BEC Brushless ESC
APC13065E	Electric Propeller, 13x6.5E
EFLAEC303	EC3 Dev & Batt, Male/Female
THP42004S2PPL	4200mAh 4S2P 14.8V Li-Po, 13GA

Or

THP38504SX 3850mAh 4S 14.8V Li-Po, 13 GA

This is a high power 3D/Aerobatic setup with very strong aggressive performance.

Alternative Sport and

Precision

Setups

EFLM4032A	Power 32 BL Outrunner, 770Kv
THP42003S2PPL	4200mAh 3S2P 11.1V Li-Po, 13GA
APC14070E	Electric Propeller, 14x7E

Or

EFLM4025A	Power 25 BL Outrunner, 870Kv
THP42004S2PPL	4200mAh 4S2P 14.8V Li-Po, 13GA
APC11080E	Electric Propeller, 11x8E

And

EFLA1060	60A Pro Switching BEC Brushless ESC
EFLAEC303	EC3 Dev & Batt, Male/Female

This is an alternative sport and precision aerobatic setup and is a good option if you have some equipment and do not want to purchase additional. Both options are very similar in performance; you should expect better performance than our lightweight sport setup and less performance than with our recommended high power precision setup.

Optional Accessories

EFLA110	Power Meter
HAN172	Hangar 9® Digital Servo and Rx Current Meter
JRPA215	Large Servo Arm (2)

Notes on Lithium Polymer Batteries



Lithium Polymer batteries are significantly more volatile than alkaline or Ni-Cd/Ni-MH batteries used in RC applications. All manufacturer's instructions and warnings must be followed closely. Mishandling of Li-Po batteries can result in fire. Always follow the manufacturer's instructions when disposing of Lithium Polymer batteries.

Warning

An RC aircraft is not a toy! If misused, it can cause serious bodily harm and damage to property. Fly only in open areas, preferably at AMA (Academy of Model Aeronautics) approved flying sites, following all instructions included with your radio. Keep loose items that can get entangled in the propeller away from the prop, including loose clothing, or other objects such as pencils and screwdrivers. Especially keep your hands away from the propeller.

Warranty Period

Horizon Hobby, Inc., (Horizon) warrants that the Products purchased (the "Product") will be free from defects in materials and workmanship at the date of purchase by the Purchaser.

Limited Warranty

(a) This warranty is limited to the original Purchaser ("Purchaser") and is not transferable. REPAIR OR REPLACEMENT AS PROVIDED UNDER THIS WARRANTY IS THE EXCLUSIVE REMEDY OF THE PURCHASER. This warranty covers only those Products purchased from an authorized Horizon dealer. Third party transactions are not covered by this warranty. Proof of purchase is required for warranty claims. Further, Horizon reserves the right to change or modify this warranty without notice and disclaims all other warranties, express or implied.

(b) Limitations- HORIZON MAKES NO WARRANTY OR REPRESENTATION, EXPRESS OR IMPLIED, ABOUT NON-INFRINGEMENT, MERCHANTABILITY OR FITNESS FOR A PARTICULAR PURPOSE OF THE PRODUCT. THE PURCHASER ACKNOWLEDGES THAT THEY ALONE HAVE DETERMINED THAT THE PRODUCT WILL SUITABLY MEET THE REQUIREMENTS OF THE PURCHASER'S INTENDED USE.

(c) Purchaser Remedy- Horizon's sole obligation hereunder shall be that Horizon will, at its option, (i) repair or (ii) replace, any Product determined by Horizon to be defective. In the event of a defect, these are the Purchaser's exclusive remedies. Horizon reserves the right to inspect any and all equipment involved in a warranty claim. Repair or replacement decisions are at the sole discretion of Horizon. This warranty does not cover cosmetic damage or damage due to acts of God, accident, misuse, abuse, negligence, commercial use, or modification of or to any part of the Product. This warranty does not cover damage due to improper installation, operation, maintenance, or attempted repair by anyone other than Horizon. Return of any goods by Purchaser must be approved in writing by Horizon before shipment.

Damage Limits

HORIZON SHALL NOT BE LIABLE FOR SPECIAL, INDIRECT OR CONSEQUENTIAL DAMAGES, LOSS OF PROFITS OR PRODUCTION OR COMMERCIAL LOSS IN ANY WAY CONNECTED WITH THE PRODUCT, WHETHER SUCH CLAIM IS BASED IN CONTRACT, WARRANTY, NEGLIGENCE, OR STRICT LIABILITY. Further, in no event shall the liability of Horizon exceed the individual price of the Product on which liability is asserted. As Horizon has no control over use, setup, final assembly, modification or misuse, no liability shall be assumed nor accepted for any resulting damage or injury. By the act of use, setup or assembly, the user accepts all resulting liability.

If you as the Purchaser or user are not prepared to accept the liability associated with the use of this Product, you are advised to return this Product immediately in new and unused condition to the place of purchase.

Law: These Terms are governed by Illinois law (without regard to conflict of law principals).

Safety Precautions

This is a sophisticated hobby Product and not a toy. It must be operated with caution and common sense and requires some basic mechanical ability. Failure to operate this Product in a safe and responsible manner could result in injury or damage to the Product or other property. This Product is not intended for use by children without direct adult supervision. The Product manual contains instructions for safety, operation and maintenance. It is essential to read and follow all the instructions and warnings in the manual, prior to assembly, setup or use, in order to operate correctly and avoid damage or injury.

Questions, Assistance, and Repairs

Your local hobby store and/or place of purchase cannot provide warranty support or repair. Once assembly, setup or use of the Product has been started, you must contact Horizon directly. This will enable Horizon to better answer your questions and service you in the event that you may need any assistance. For questions or assistance, please direct your email to productsupport@horizonhobby.com, or call 877.504.0233 toll free to speak to a service technician.

Inspection or Repairs

If this Product needs to be inspected or repaired, please call for a Return Merchandise Authorization (RMA). Pack the Product securely using a shipping carton. Please note that original boxes may be included, but are not designed to withstand the rigors of shipping without additional protection. Ship via a carrier that provides tracking and insurance for lost or damaged parcels, as *Horizon is not responsible for merchandise until it arrives and is accepted at our facility*. A Service Repair Request is available at www.horizonhobby.com on the "Support" tab. If you do not have internet access, please include a letter with your complete name, street address, email address and phone number where you can be reached during business days, your RMA number, a list of the included items, method of payment for any non-warranty expenses and a brief summary of the problem. Your original sales receipt must also be included for warranty consideration. Be sure your name, address, and RMA number are clearly written on the outside of the shipping carton.

Warranty Inspection and Repairs

To receive warranty service, you must include your original sales receipt verifying the proof-of-purchase date. Provided warranty conditions have been met, your Product will be repaired or replaced free of charge. Repair or replacement decisions are at the sole discretion of Horizon Hobby.

Non-Warranty Repairs

Should your repair not be covered by warranty the repair will be completed and payment will be required without notification or estimate of the expense unless the expense exceeds 50% of the retail purchase cost. By submitting the item for repair you are agreeing to payment of the repair without notification. Repair estimates are available upon request. You must include this request with your repair. Non-warranty repair estimates will be billed a minimum of ½ hour of labor. In addition you will be billed for return freight. Please advise us of your preferred method of payment. Horizon accepts money orders and cashiers checks, as well as Visa, MasterCard, American Express, and Discover cards. If you choose to pay by credit card, please include your credit card number and expiration date. Any repair left unpaid or unclaimed after 90 days will be considered abandoned and will be disposed of accordingly. *Please note: non-warranty repair is only available on electronics and model engines.*

Electronics and engines requiring inspection or repair should be shipped to the following address:

Horizon Service Center
4105 Fieldstone Road
Champaign, Illinois 61822

All other Products requiring warranty inspection or repair should be shipped to the following address:

Horizon Product Support
4105 Fieldstone Road
Champaign, Illinois 61822

Please call 8 -50 -0233 with any questions or concerns regarding this product or warranty.

Safety, Precautions, and Warnings

As the user of this product, you are solely responsible for operating it in a manner that does not endanger yourself and others or result in damage to the product or the property of others.

Carefully follow the directions and warnings for this and any optional support equipment (chargers, rechargeable battery packs, etc.) that you use.

This model is controlled by a radio signal that is subject to interference from many sources outside your control. This interference can cause momentary loss of control so it is necessary to always keep a safe distance in all directions around your model, as this margin will help to avoid collisions or injury.

- Always operate your model in an open area away from cars, traffic, or people.
- Avoid operating your model in the street where injury or damage can occur.
- Never operate the model out into the street or populated areas for any reason.
- Never operate your model with low transmitter batteries.
- Carefully follow the directions and warnings for this and any optional support equipment (chargers, rechargeable battery packs, etc.) that you use.
- Keep all chemicals, small parts and anything electrical out of the reach of children.
- Moisture causes damage to electronics. Avoid water exposure to all equipment not specifically designed and protected for this purpose.

Instructions for Disposal of WEEE by Users in the European Union

This product must not be disposed of with other waste. Instead, it is the user's responsibility to dispose of their waste equipment by handing it over to a designated collection point for the recycling of waste electrical and electronic equipment. The separate collection and recycling of your waste equipment at the time of disposal will help to conserve natural resources and ensure that it is recycled in a manner that protects human health and the environment. For more information about where you can drop off your waste equipment for recycling, please contact your local city office, your household waste disposal service or where you purchased the product.



Landing Gear Installation

Required Parts

- Fuselage
- Main landing gear
- Wheel pant (left & right)
- 2 3/4-inch (70mm) wheel (2)
- 4-40 x 1/2-inch socket head screw (2)
- #4 washers (6)
- 4mm locknut (4)
- 4mm x 35mm machine screw (2)
- 2mm x 8mm wood screws (4)

Required Tools and Adhesives

- Phillips screwdriver (small)
- Needle-nose pliers
- Nut driver: 7mm
- Hex wrench: 3/32-inch

1. Place the landing gear onto the bottom of the fuselage. Attach with two 4-40 x 1/2-inch socket head screws and two #4 washers.

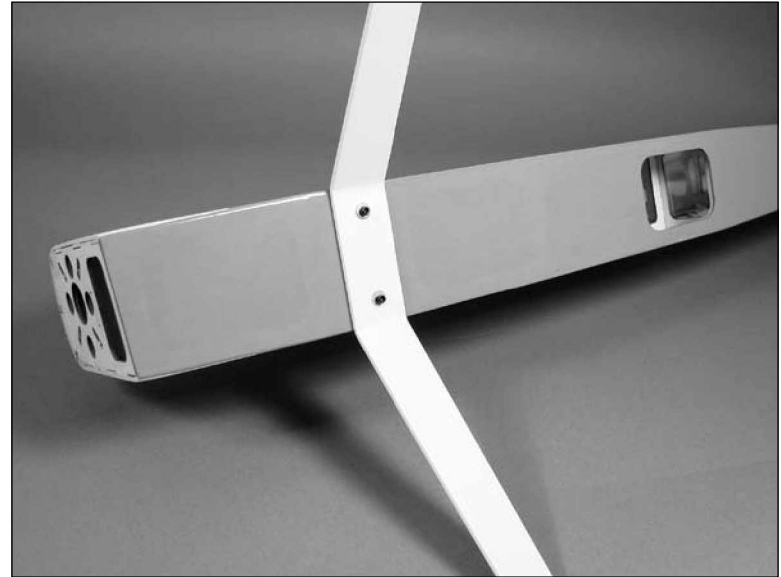

2. Slide the 4mm x 35mm machine screw through one of the 2 3/4-inch wheels. Secure a 4mm lock nut against the wheel. Make sure the wheel still spins freely.

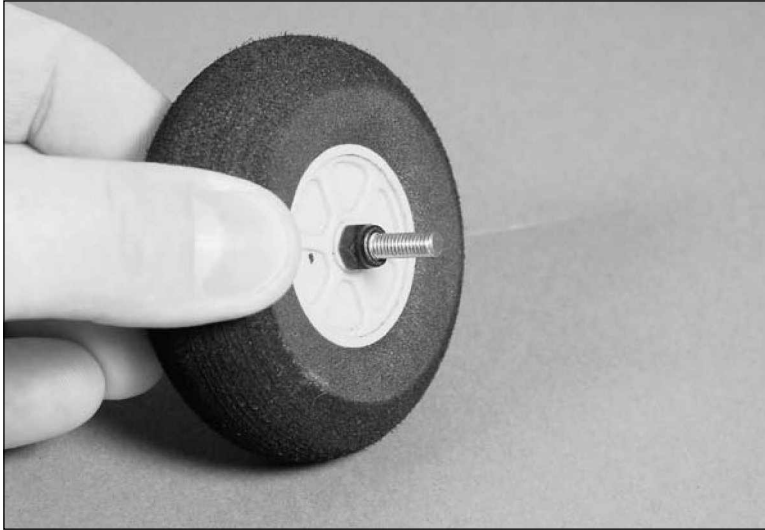

3. Attach the wheel to the landing gear using a 4mm washer and a 4mm lock nut. Leave the nut loose at this time.

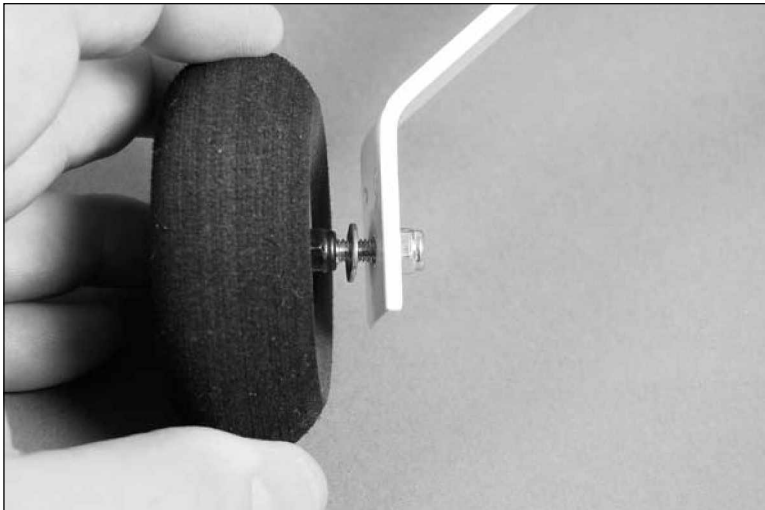

4. Slide the wheel pant over the wheel. The 4mm washer will be inside the wheel pant. Use two 2mm x 8mm sheet metal screws threaded into the pre-drilled holes to attach the wheel pant to the landing gear. Tighten the 4mm lock nut using a 7mm nut driver to complete the assembly.



5. Repeat Steps 2 through 4 for the remaining wheel and wheel pant.

Motor Installation

Required Parts

- Fuselage assembly
- Hook and loop strap (2)
- Cowling
- Propeller
- 4-40 x 3/8-inch socket head screws
- Hook and loop tape, 3-inch (76mm) (2)
- 2mm x 10mm sheet metal screw (4)
- 4-40 blind nut (4)
- 2 1/2-inch (64mm) spinner
- Brushless ESC

Required Tools and Adhesives

- Hex wrench: 3/32-inch
- Drill
- Drill bit: 1/16 in (1.5mm)
- Phillips screwdriver #0

Note: The firewall incorporates our new adjustable mount system, enabling the modeler to install a variety of outrunner motors.

1. Remove the hatch from the fuselage by lifting up at the front of the hatch. The hatch is held at the front using a magnet, and the rear using dowels.

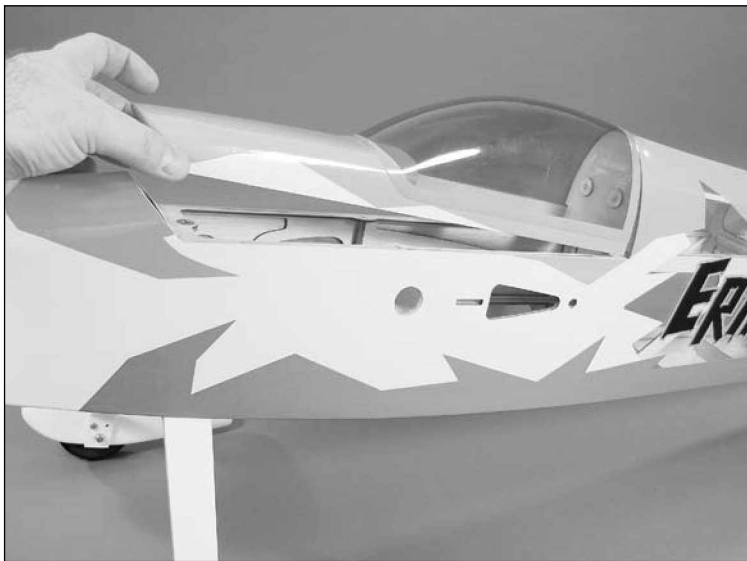

2. Attach the mount to the motor using the hardware provided with the motor.



3. Use four 4-40 x 3/8-inch socket head screws to secure the motor to the firewall. The blind nuts installed behind the firewall can be moved to allow for the mounting of various sizes of motors.

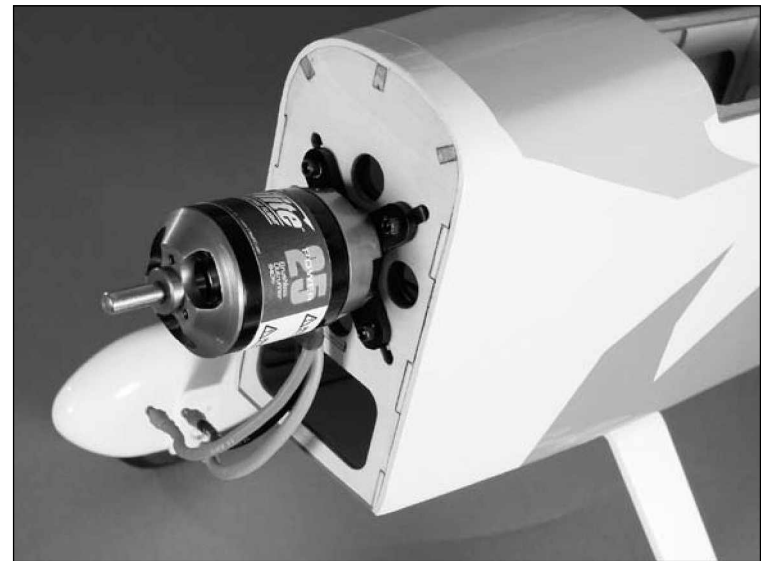

3. Plug the motor into the speed control. Use hook and loop tape to secure the speed control inside the fuselage out of the way of the battery.

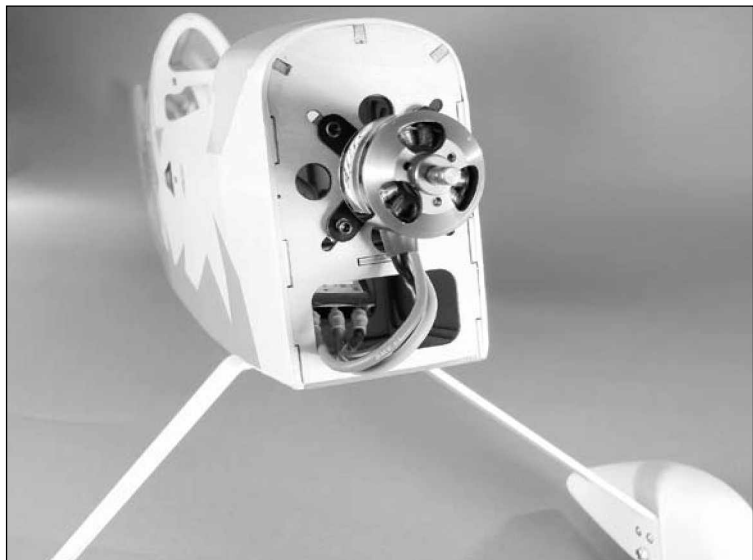

Note: When using our recommended E-flite 60A Pro Brushless ESC with switching BEC you do not need a separate receiver pack as long as you are using our recommended servos.

If your ESC is not capable of supporting the current draw of four mini-size servos the speed control may shut down due to high heat.

In order to provide the most reliable product, E-flite recommends the use of a separate BEC (like the Ultimate BEC), or receiver pack and switch to ensure trouble-free operation as follows:

Use the battery and switch harness to power the receiver and servos after disabling the BEC on the ESC (by following the instructions included with the ESC).

4. Use the two hook and loop straps included with your plane to secure the battery inside the fuselage.

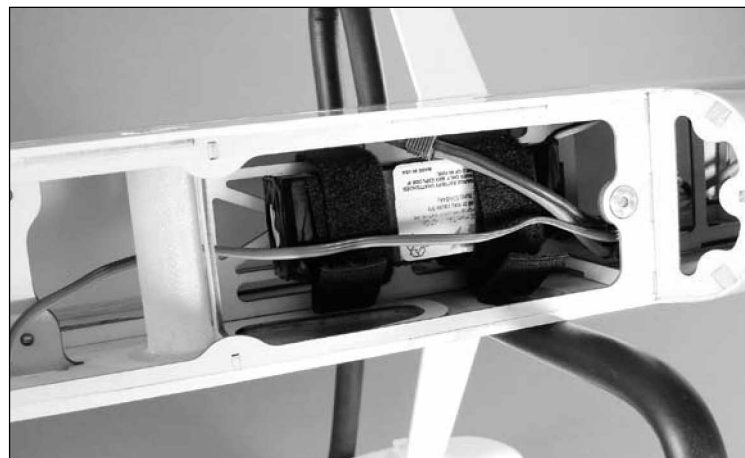

Note: If the battery slides forward or backward, use hook and loop tape on the battery and inside the fuselage to prevent the battery from moving.

5. Now is a good time to test the operation of the motor. Use your radio system and plug the speed control into the receiver. With the battery plugged in, use the throttle stick to operate the motor. Check that the motor operates properly, and that it rotates counterclockwise when viewed from the front of the plane. Follow the instructions provided with the speed control to correct for operational problems.

7. Slide the cowling onto the fuselage. Use the propeller adapter to attach the propeller and spinner backplate temporarily onto the motor. Position the cowling so it lines up with the spinner backplate, and has a small gap between the spinner backplate and cowling.



8. With the cowl aligned with the spinner, use a drill and 1/16-inch (1.5mm) drill bit to drill through the cowl and into the fuselage using the holes in the cowling.



9. Secure the cowling using the four 2mm x 6mm sheet metal screws. There are two screws on each side of the cowl as shown. Complete the cowling installation by attaching the spinner cone using the two screws provided with the spinner.

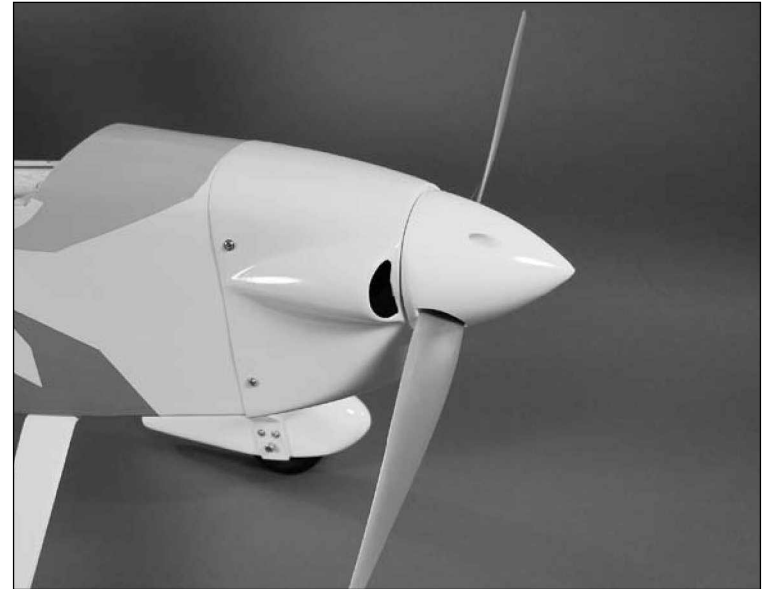

Aileron Installation

Required Parts

- Wing
- Servo w/hardware (2)
- CA hinge (8)
- Clevis (2)
- Nylon control horn (2)
- Control horn standoff (2)
- 2 7/8-inch (73mm) pushrod wire (2)
- Pushrod wire connector (2)
- Receiver
- Long servo arm (2)
- Clevis retainer (2)
- 3mm x 30mm machine screw (2)
- Control horn washer (2)

Required Tools and Adhesives

- Rotary tool
- T-pins
- Felt-tipped pen
- Threadlock
- #1 Phillips screwdriver
- Drill bit: 1/16-inch (1.5mm)
- Thin CA
- Pen drill
- Side cutters

1. Locate four CA hinges. Place a T-pin in the center of each hinge.

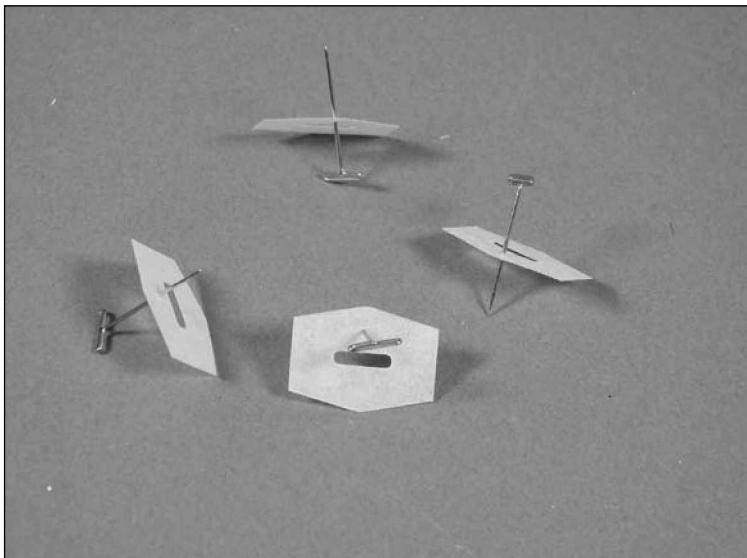

2. Use a rotary tool and a 1/16-inch (1.5mm) drill bit to drill a hole in the center of each hinge slot of both the aileron and wing. This provides a tunnel for the CA to wick into, penetrating the hinge.

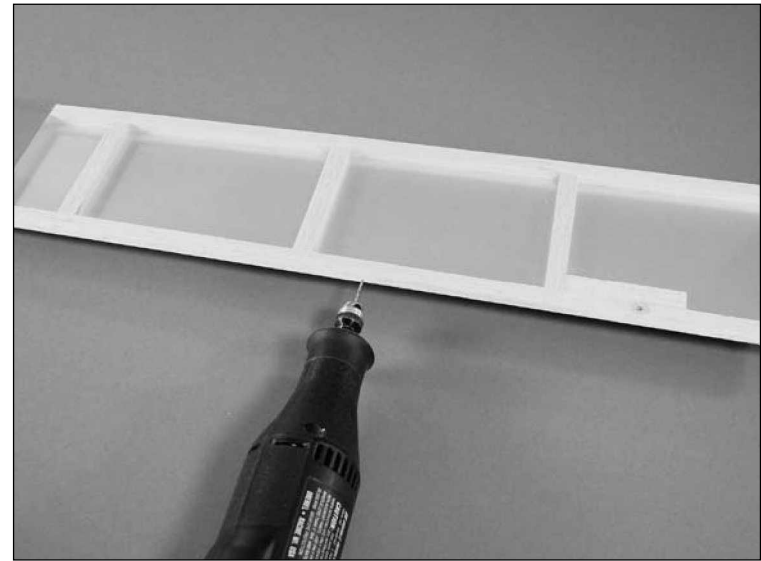

Hint: You can prepare the rudder, fin, elevator and stabilizer at this time as well.

3. Slide the four hinges into the slots in the aileron.

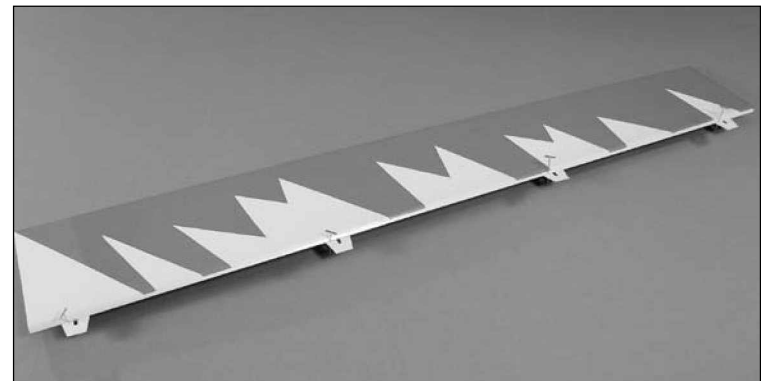

4. Slide the aileron into position on the wing. The T-pins installed in the hinges will help in keeping equal amounts in the wing and aileron.

5. Align the aileron with the wing tip. Apply a few drops onto each hinge. Make sure to apply the CA on both the top and bottom of the hinge.

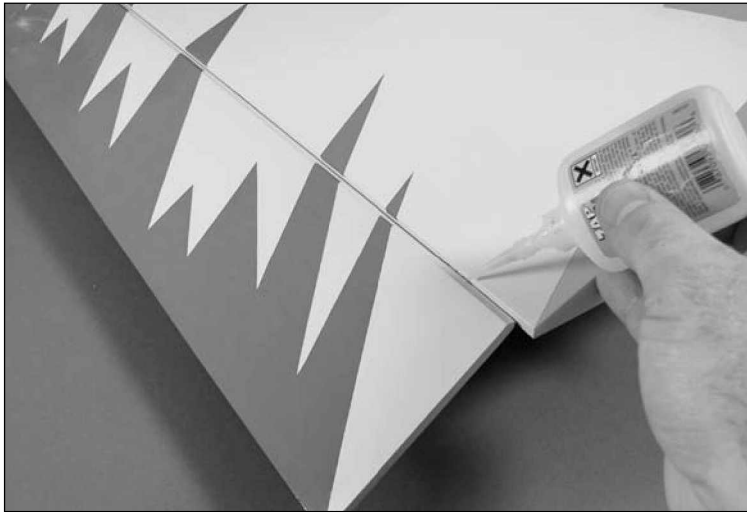

Important: Do not use accelerator on the hinges. The CA must be allowed to soak in and penetrate the hinge.

Note: Placing a #11 hobby blade between the aileron leading edge and wing trailing edge to position the aileron will result in a nice free-moving hinge for 3D throws without any binding.

6. Gently pull the aileron from the wing once the CA has fully cured. This is to verify the hinges are glued securely.

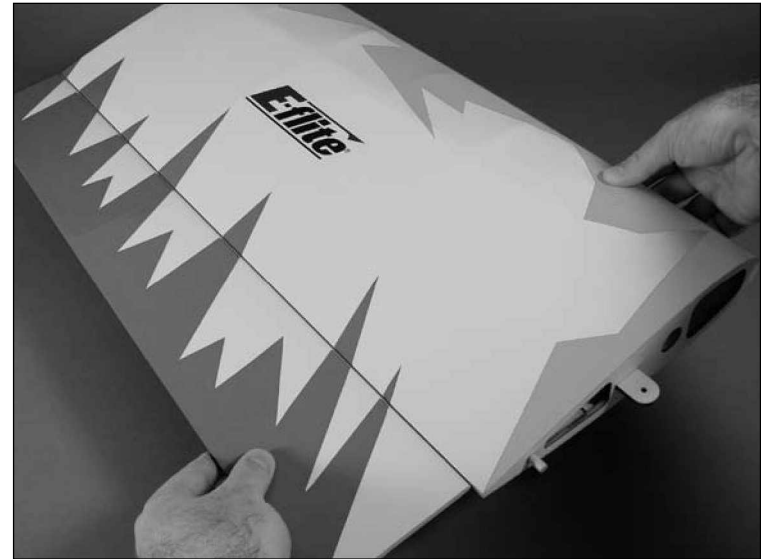

7. Flex the aileron through its range of motion a few times to break in the hinges.

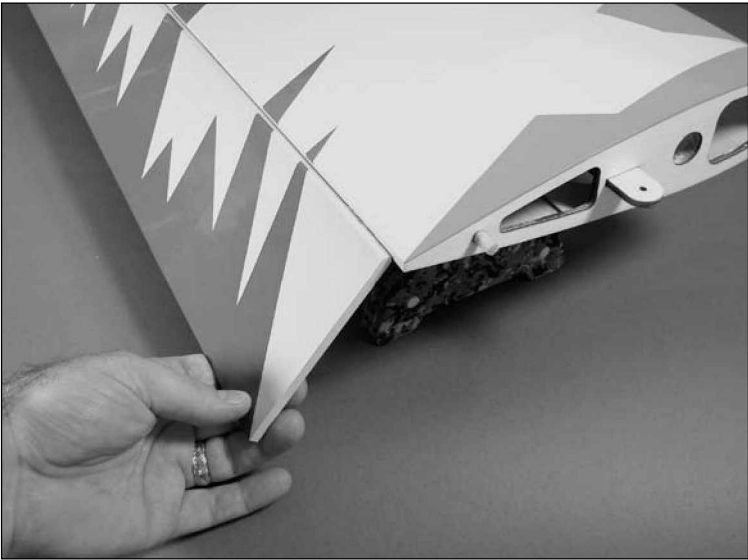
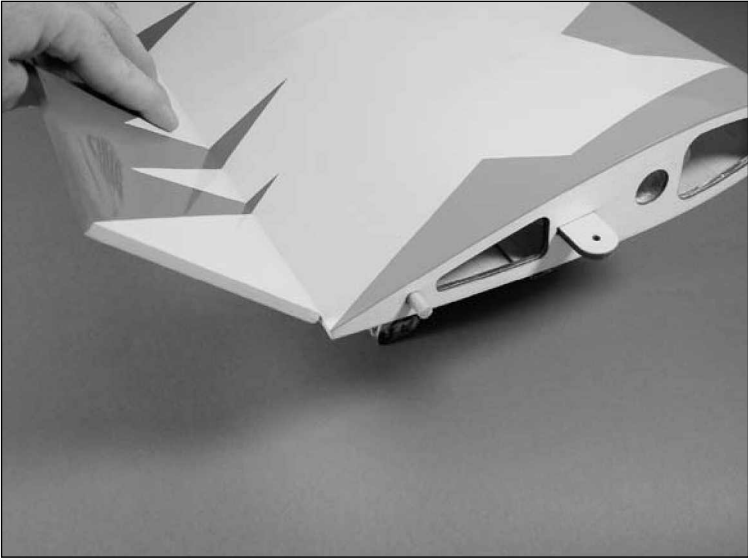

8. Repeat Steps 1 through 7 to complete the aileron installation.

9. Place the servo into the opening in the wing. Use a felt-tipped pen to mark the locations for the servo mounting screws.



10. Use a pen drill and 1/16-inch (1.5mm) drill bit to drill the four locations for the servo mounting screws.

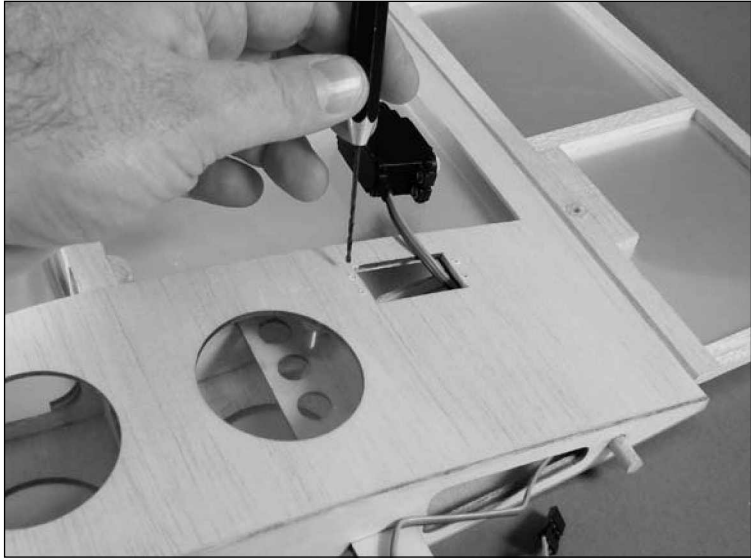

11. Apply a few drops of thin CA to each of the four holes. This will harden the underlying wood and help in preventing the screws from pulling out.

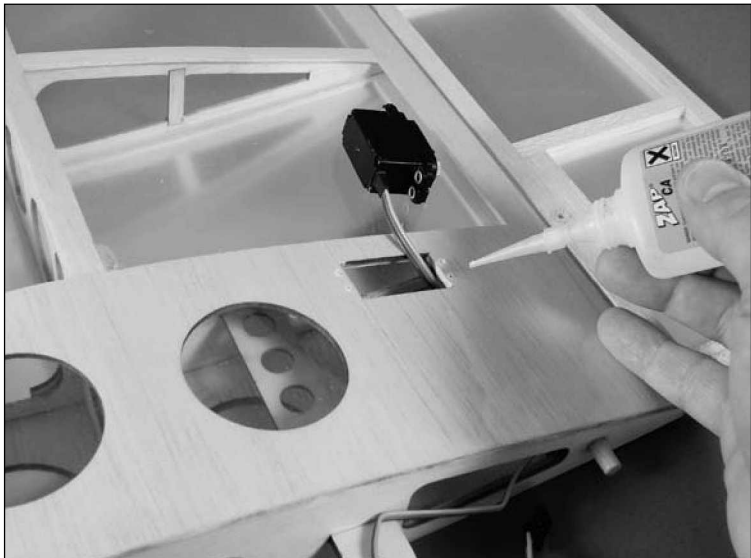

12. Secure the servo in the wing using the screws provided with the servo. Note the servo horn faces towards the aileron.



13. Use a hobby knife to pierce the covering for the 3mm x 30mm machine screw. Slide the screw into the hole from the top of the wing. Slide a control horn washer onto the screw, then thread the control horn standoff onto the screw. Use a #1 Phillips screwdriver to tighten the assembly.

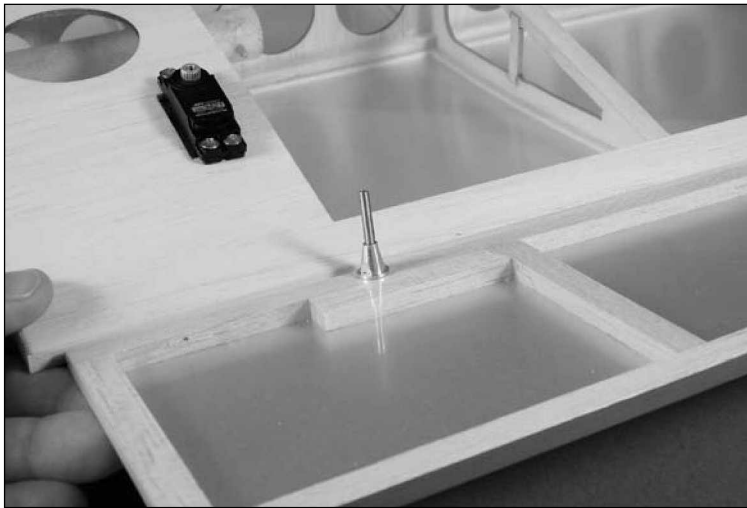
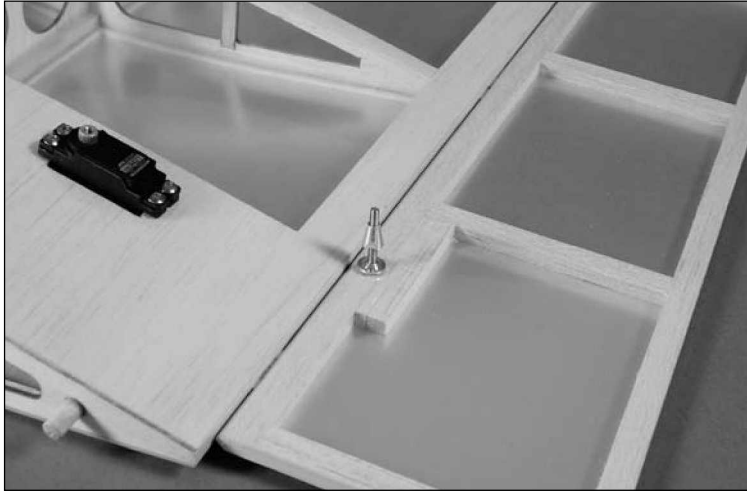

Note: Use threadlock on the control horn screw to prevent it from vibrating loose.

14. Thread the nylon control horn onto the control horn screw until the top of the horn is flush with the top of the screw.

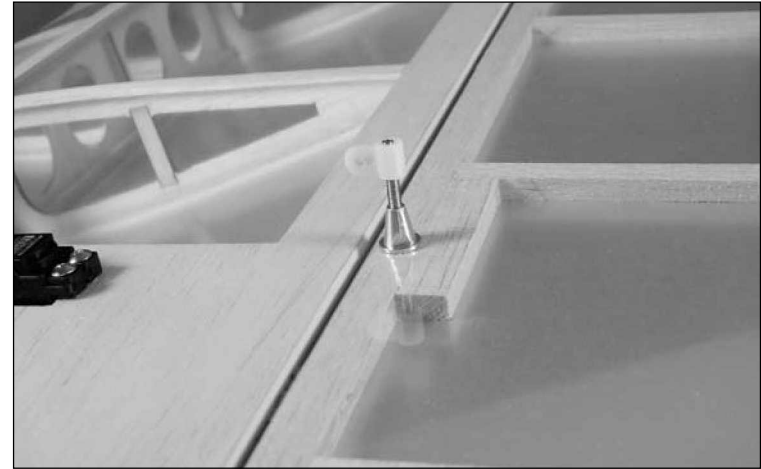

15. Slide a clevis retainer onto a nylon clevis. Thread the clevis onto the 2 7/8-inch (73mm) pushrod wire. Attach the clevis to the control horn and slide the clevis retainer over the forks of the clevis to secure it to the control horn.

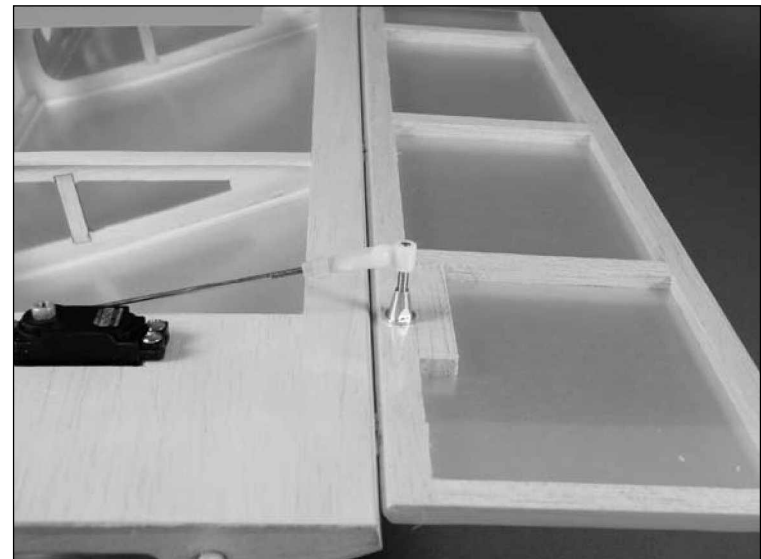

16. Use a pushrod wire connector to secure the wire to the servo arm. Trim any excess wire using side cutters.

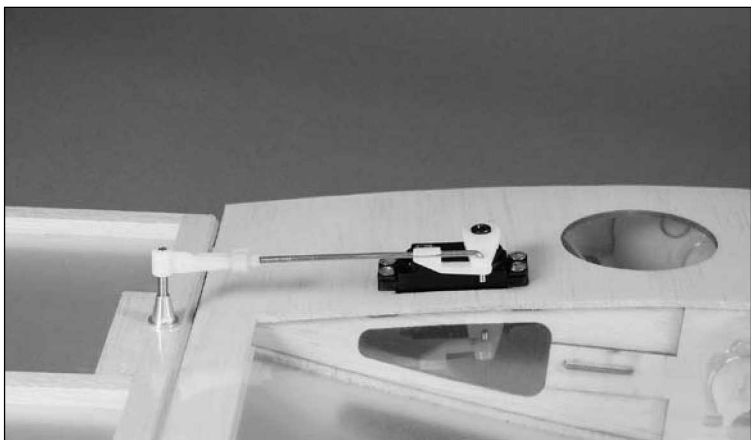

17. Repeat Steps 9 through 16 to complete the aileron servo installation.

Wing Installation

Required Parts

- Fuselage
- Wing (right and left)
- Wing tube
- #4 washer (2)
- 4-40 x $\frac{1}{2}$ -inch machine screw (2)

Required Tools and Adhesives

- Hex wrench: 3/32-inch

1. Slide the wing tube into a wing panel.



2. Remove the hatch from the fuselage. Slide the wing panel with tube into position on the fuselage.



3. Slide the remaining wing panel into position. Secure the panels using 4-40 x 1/2-inch machine screws with #4 washers (silver) using a 3/32-inch hex wrench.



4. Repeat Steps 2 and 3 for the remaining wing panel.

Stabilizer and Elevator

Required Parts

- Fuselage w/wing installed
- Stabilizer
- CA hinge (4)
- Elevator
- Elevator joiner wire

Required Tools and Adhesives

- Hobby knife
- Ruler
- Thin CA
- 30-minute epoxy
- Felt-tipped pen
- T-pins
- Sandpaper

1. Position the stabilizer into the slot in the aft end of the fuselage. Check that the stabilizer is centered in the fuselage.

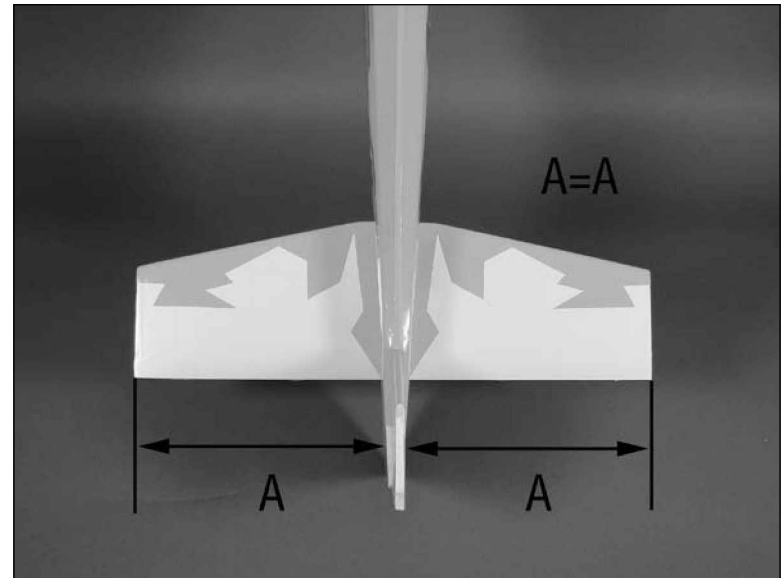

2. Measure from the stab tip to the wing tip. Adjust the stab until the measurements are equal.

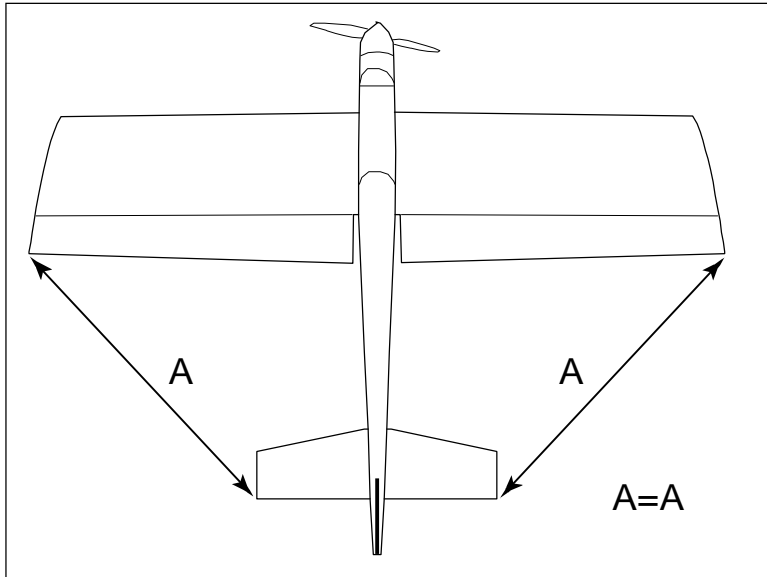

3. View the airframe from the rear and make sure the wing and stab are parallel. If not, lightly sand the stab saddle until they are.

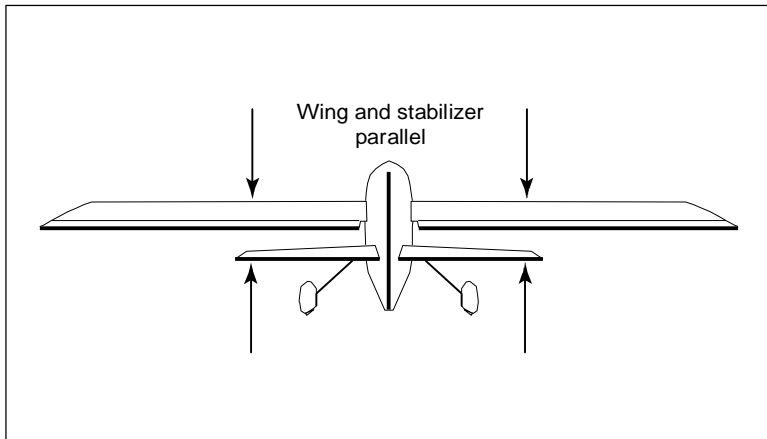

4. Double-check the adjustments from Steps 1 through 3. Use a felt-tipped pen to trace the outline of the fuselage onto the top and bottom of the stabilizer.

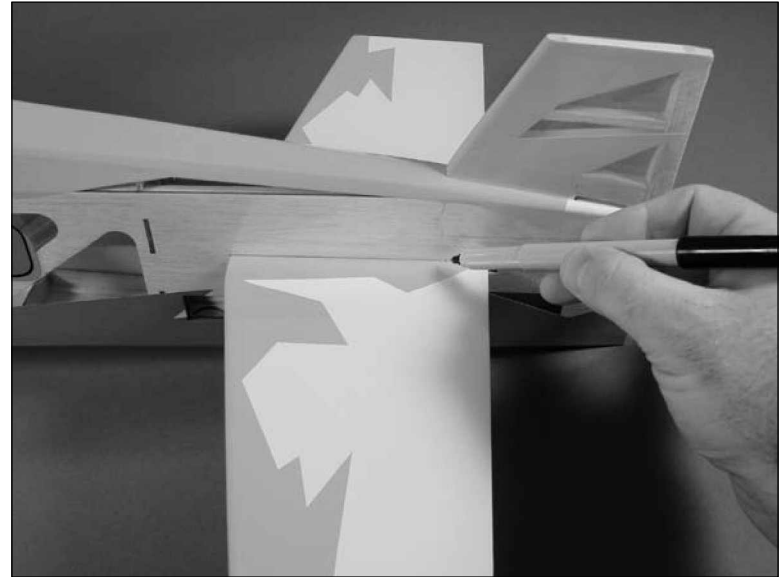

5. Use a sharp hobby knife to cut the covering slightly inside the lines drawn. Be very careful not to cut into the underlying wood, as this will weaken the stab and cause it to fail in flight.

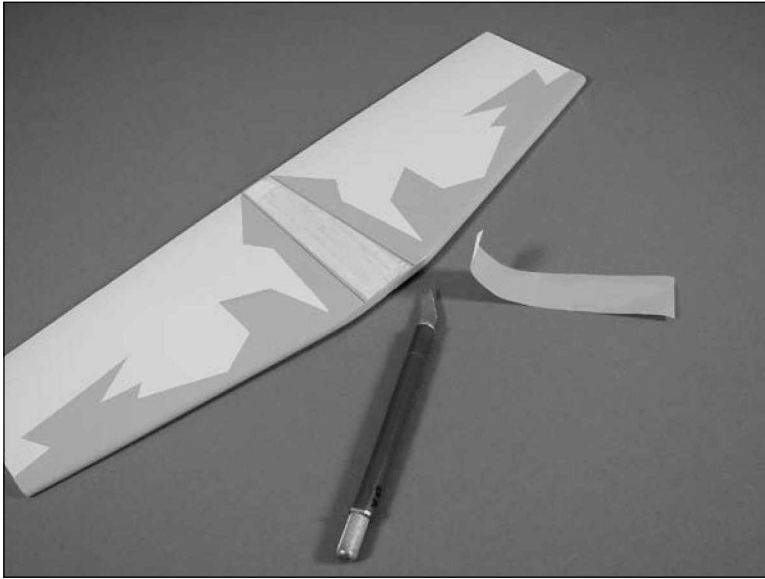

Note: You can use a soldering iron instead of a knife. This will eliminate the chances of cutting into the wood.

6. Slide the elevator jointer into position, then the stabilizer.

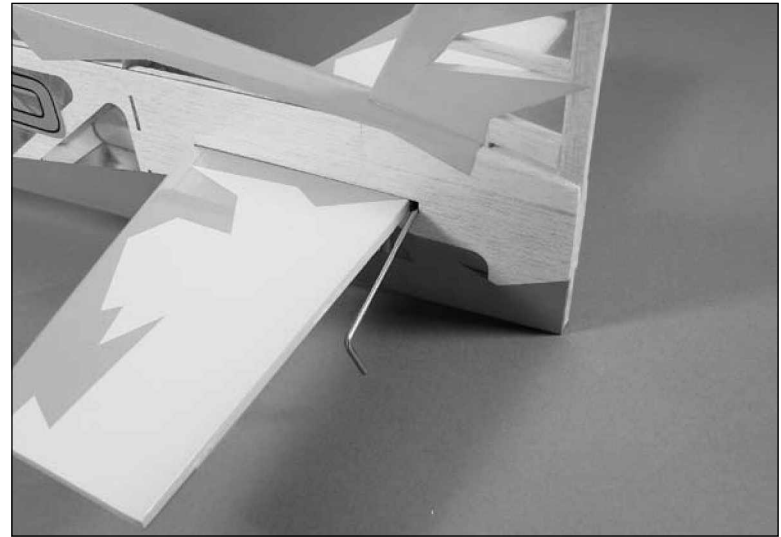

7. Check the alignment and make sure everything lines up. Wick thin CA into the joint between the fuselage and stabilizer. Make sure to glue both top and bottom. Do not use accelerator— to allow the CA to wick in the joint, providing the best bond possible.

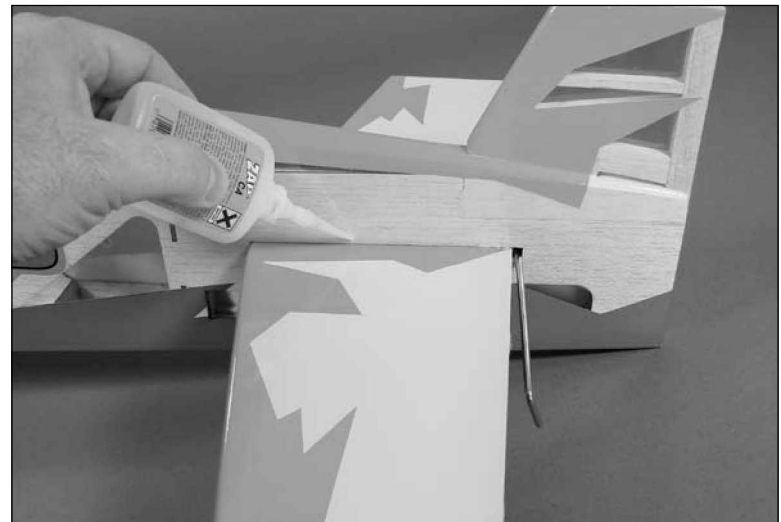

8. Prepare two CA hinges by placing a T-pin in the center of each hinge. Test fit the elevator against the stabilizer. Make sure the joiner wire fits into the elevator as well.



9. Roughen the joiner wire using medium grit sandpaper. Apply 30-minute epoxy to the joiner wire and in the hole in the elevator as well.

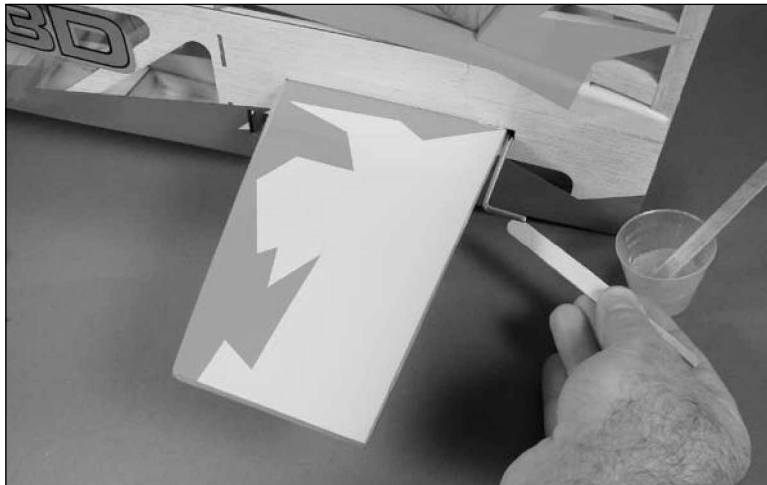

10. Follow the same procedure for hinging the ailerons to hinge the stabilizer/elevator.

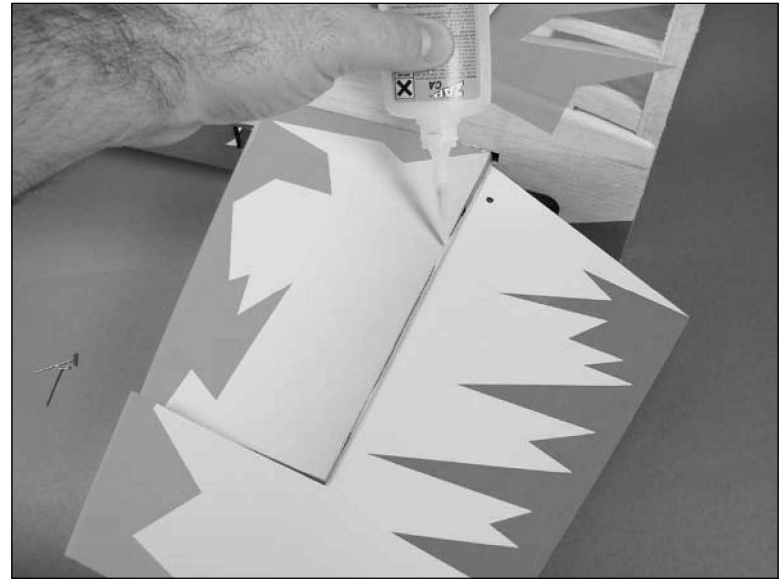

11. Repeat Steps 8 through 10 for the remaining elevator.

Rudder and Fin

Required Parts

- Fuselage
- Fin
- Tail wheel assembly
- Wheel collar w/setscrew
- Rudder
- CA hinge (3)
- Tailwheel

Required Tools and Adhesives

- Hobby knife
- 30-minute epoxy
- Hex wrench: 1.5mm
- Thin CA
- Medium grit sandpaper

1. Roughen the tail wheel assembly using medium grit sandpaper. Use 30-minute epoxy to glue the tail wheel assembly into the fuselage.

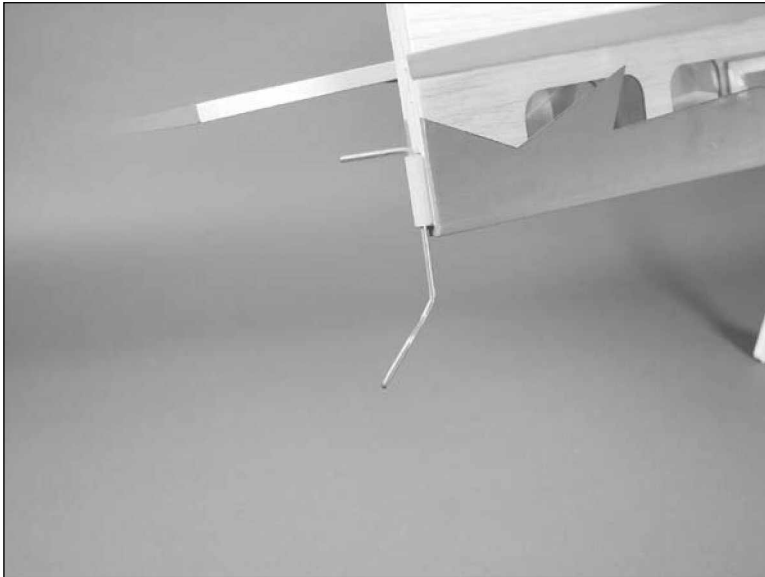

2. Hinge the rudder and fin, using the same process as described in Aileron Hinging. Use three hinges for this process. Make sure to install the tail wheel into the rudder as well, gluing it with 30-minute epoxy.

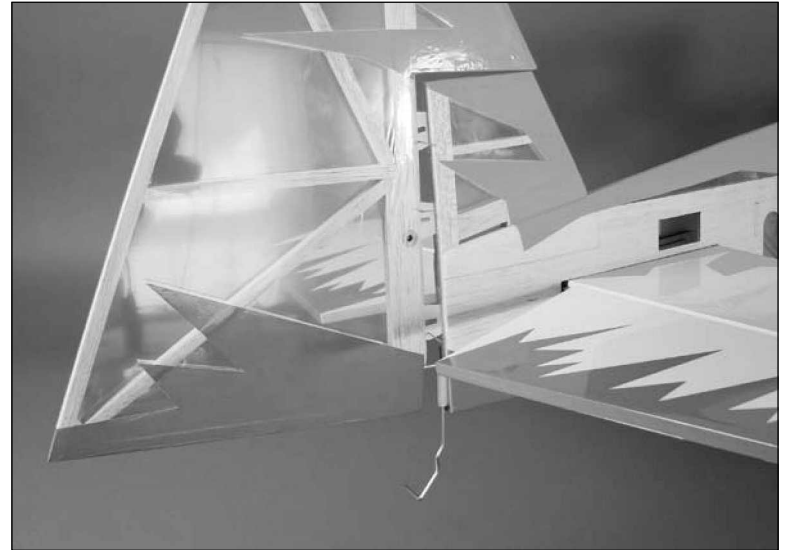

3. Install the tail wheel using the wheel collar and setscrew. Use a 1.5mm hex wrench to tighten the setscrew.



Rudder and Elevator Servos

Required Parts

- Fuselage
- Long servo arm (2)
- Clevis (2)
- Nylon control horn (2)
- Control horn standoff (2)
- 4-inch (102mm) pushrod wire
- 5 1/2-inch (140mm) pushrod wire
- 12-inch (305mm) servo extension (2)
- Pushrod wire connector (2)
- Servo (2)
- Clevis retainer (2)
- 3mm x 30mm machine screw (2)
- Control horn washer (2)

Required Tools and Adhesives

- Phillips screwdriver (small)
- 30-minute epoxy
- String or dental floss
- Hobby knife
- Threadlock

1. Secure a 12-inch (305mm) servo extension to the servo. Mount the elevator servo using the hardware provided with the servo.

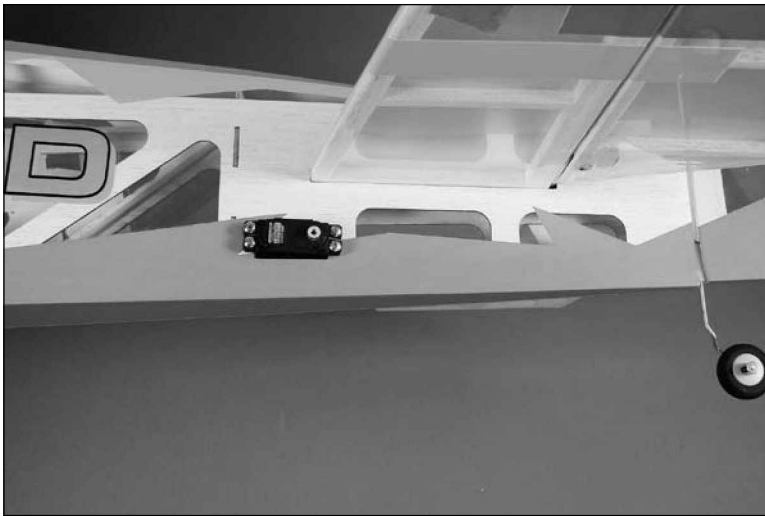

Note: Use string or dental floss to secure the servo lead to the servo extension so they don't become unplugged during flight.

2. Attach the control horn in position on the rudder and elevator using the same technique as the aileron control horns.

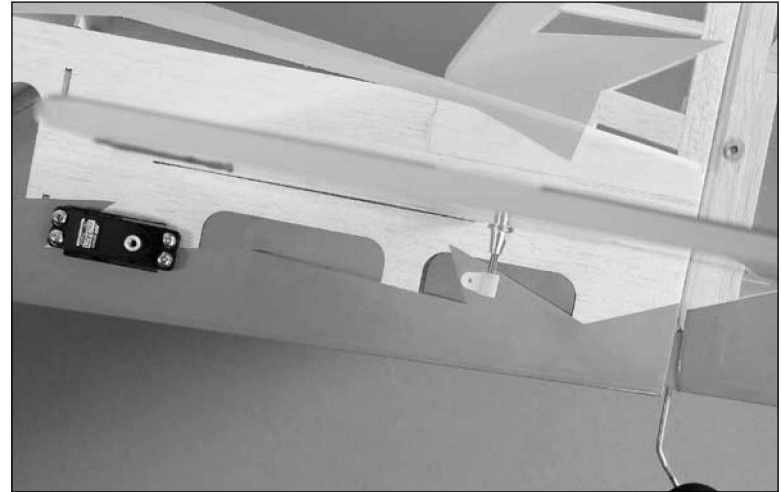

Note: Use threadlock on the control horn screw to prevent it from vibrating loose.

4. Assemble the elevator linkage using the 4-inch (102mm) pushrod wire. Attach the linkage to a long servo arm with a pushrod connector.

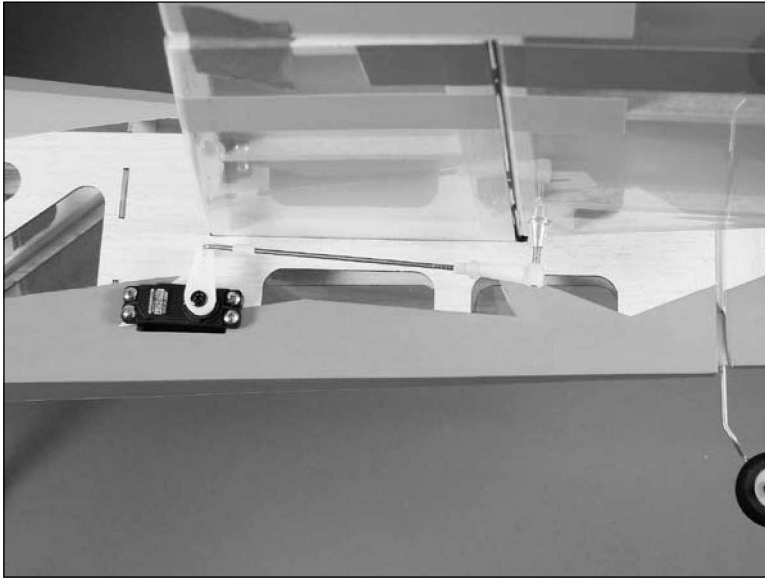

5. Repeat Steps 1 through 4 for the rudder servo and linkage using the 5 1/2-inch (140mm) pushrod wire.

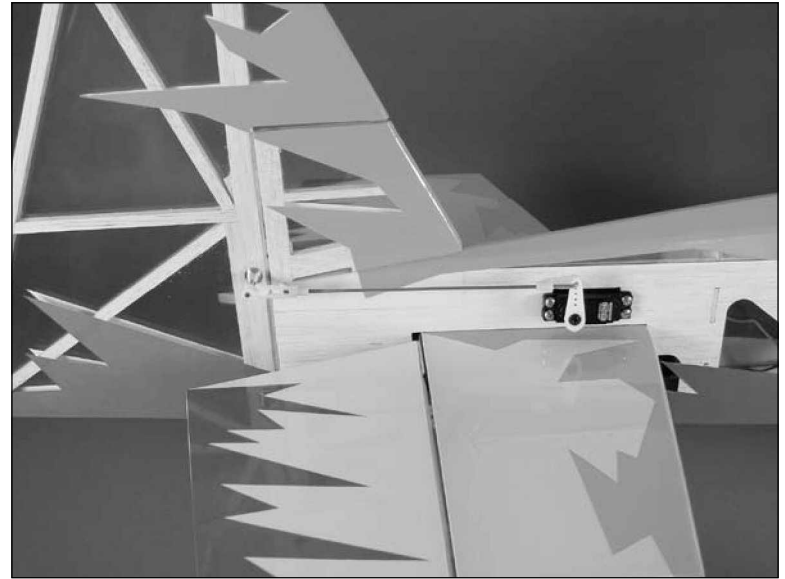

6. Plug the elevator servo, rudder servo and ESC into the receiver. Mount the receiver to the inside of the fuselage using hook and loop material. Route the antenna wire through the bottom of the fuselage to the rear, or as directed by your radio instruction manual.

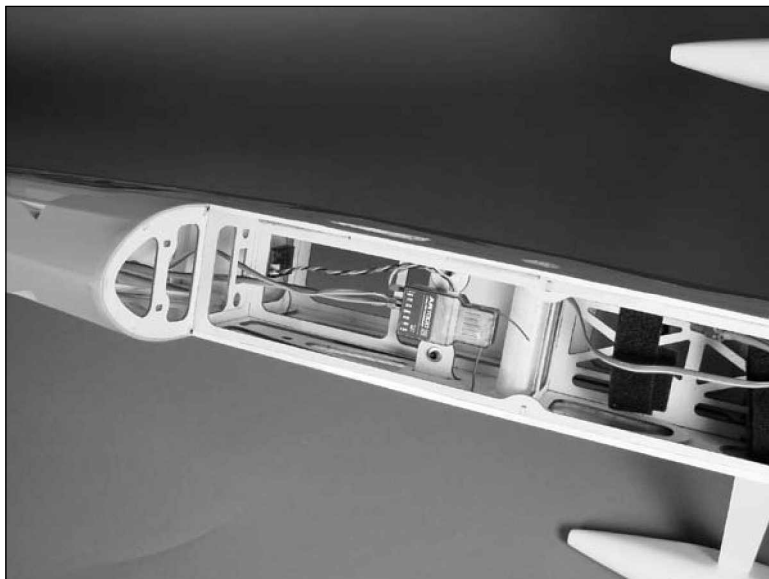

Note: Do not cut or change the length of the antenna wire, as this will reduce the range of your radio system.

Control Throws

1. Turn on the transmitter and receiver of your aircraft. Check the movement of the rudder using the transmitter. When the stick is moved right, the rudder should also move right. Reverse the direction of the servo at the transmitter if necessary.
2. Check the movement of the ailerons using the transmitter. When the stick is moved right, the right aileron will move up and the left aileron will move down. Reverse the direction of the servo at the transmitter if necessary.
3. Check the movement of the elevator with the radio system. Moving the elevator stick down will make the airplane elevator move up.
4. Use a throw gauge to adjust the throw of the elevator, ailerons and rudder. Adjust the position of the pushrod at the control horn, or the travel/endpoint adjustments of your computer transmitter, to achieve the following measurements when moving the sticks to their endpoints.

The control throw measurements are taken at the widest point on the surface.

	<i>Low Rate</i>	<i>High Rate</i>
<i>Ailerons:</i>		
Up	1-inch (25mm)	3-inch (76mm)
Down	1-inch (25mm)	3-inch (76mm)
<i>Elevator:</i>		
Up	1-inch (25mm)	3 1/2-inch (90mm)
Down	1-inch (25mm)	3 1/2-inch (90mm)
<i>Rudder:</i>		
Right	2-inch (51mm)	4 1/2-inch (114mm)
Left	2-inch (51mm)	4 1/2-inch (114mm)

These are general guidelines measured from our own flight tests. You can experiment with higher rates to match your preferred style of flying.



Center of Gravity

An important part of preparing the aircraft for flight is properly balancing the model.

Caution: Do not inadvertently skip this step!

The recommended Center of Gravity (CG) location for the Eratix 3D 25e is 3 1/4 inches (83mm) to 4 inches (102mm) back measured from the center of the leading edge of the wing next to the fuselage.

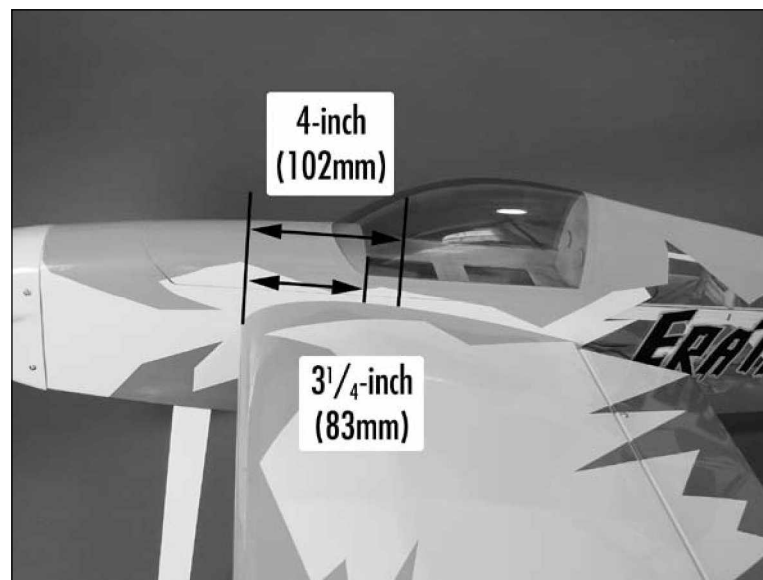

After your first flights, the Center of Gravity can be adjusted for personal preference.

Range Test Your Radio

1. Before each flying session, be sure to range check your radio. This is accomplished by turning on your transmitter with the antenna collapsed. Turn on the receiver in your airplane. With your airplane on the ground and the engine running, you should be able to walk 30 paces (approximately 100 feet) away from your airplane and still have complete control of all functions.

If not, don't attempt to fly! Have your radio equipment checked out by the manufacturer.

2. Double-check that all controls (aileron, elevator, rudder and throttle) move in the correct direction.

3. Be sure that your transmitter batteries are fully charged, per the instructions included with your radio.

Preflight

Check Your Radio

Before going to the field, be sure that your batteries are fully charged per the instructions included with your radio. Charge both the transmitter and receiver pack for your airplane. Use the recommended charger supplied with your particular radio system, following the instructions provided with the radio. In most cases, the radio should be charged the night before going out flying.

Before each flying session, be sure to range check your radio. See your radio manual for the recommended range and instructions for your radio system. Each radio manufacturer specifies different procedures for their radio systems. Next, start the motor. With the model securely anchored, check the range again. The range test should not be significantly affected. If it is, don't attempt to fly! Have your radio equipment checked out by the manufacturer.

Note: Keep loose items that can get entangled in the propeller away from the prop. These include loose clothing, or other objects such as pencils and screwdrivers. Especially keep your hands away from the propeller.

Double-check that all controls (aileron, elevator, rudder and throttle) move in the correct direction.

Check the radio installation and make sure all the control surfaces are moving correctly (i.e. the correct direction and with the recommended throws). Test run the motor and make sure it transitions smoothly from off to full throttle and back. Also ensure the engine is installed according to the manufacturer's instructions, and it will operate consistently.

Check all the control horns, servo horns, and clevises to make sure they are secure and in good condition. Replace any items that would be considered questionable. Failure of any of these components in flight would mean the loss of your aircraft.

Flying Your Eratix 3D 25e

Flying the Eratix 3D 25e is about as fun as it can get at the field. A very light wing loading and extreme control throws make for some exciting 3D flying. Verify that your CG is at the correct location as per the manual and that you have your rates set up to your liking. Verify all control throws are in the correct direction and the motor spins in the correct direction as well. Point the model into the wind and add some throttle trim until the motor begins to turn. This will be your flight idle. Now, apply power slowly. You will find the model will become airborne very quickly and at a low speed. This model excels at flying slow and easy as well as fast and extreme. Trim the model for level flight at half throttle. Only use full throttle for maneuvering. It is not recommended to fly this model fast or at full throttle in level flight. Doing this can result in the flight controls fluttering and a potential catastrophic failure of the airframe.

You will find you can adjust the CG to your liking by moving the battery pack fore or aft on the fuselage. Also keep the battery on the fuselage mounted high (at least at wing centerline or above) to help in hovering maneuvers and harriers.

To land the Eratix 3D 25e just reduce the throttle to idle and feed in up elevator until the model settles into a slightly nose high attitude. Gently fly the model down to the landing spot with a final flair at touchdown. You will find the model will have a very short roll out. We hope you enjoy the Eratix 3D 25e as much as we do.

Happy landings.

2007 Official AMA National

Model Aircraft Safety Code

GENERAL

- 1) I will not fly my model aircraft in sanctioned events, air shows or model flying demonstrations until it has been proven to be airworthy by having been previously, successfully flight tested.
- 2) I will not fly my model higher than approximately 400 feet within 3 miles of an airport without notifying the airport operator. I will give right-of-way and avoid flying in the proximity of full-scale aircraft. Where necessary, an observer shall be utilized to supervise flying to avoid having models fly in the proximity of full-scale aircraft.
- 3) Where established, I will abide by the safety rules for the flying site I use, and I will not willfully or deliberately fly my models in a careless, reckless and/or dangerous manner.
- 4) The maximum takeoff weight of a model is 55 pounds, except models flown under Experimental Aircraft rules.
- 5) I will not fly my model unless it is identified with my name and address or AMA number on or in the model. (This does not apply to models while being flown indoors.)
- 6) I will not operate models with metal-bladed propellers or with gaseous boosts, in which gases other than air enter their internal combustion engine(s); nor will I operate models with extremely hazardous fuels such as those containing tetranitromethane or hydrazine.

RADIO CONTROL

- 1) I will have completed a successful radio equipment ground range check before the first flight of a new or repaired model.
- 2) I will not fly my model aircraft in the presence of spectators until I become a qualified flier, unless assisted by an experienced helper.
- 3) At all flying sites a straight or curved line(s) must be established in front of which all flying takes place with the other side for spectators. Only personnel involved with flying the aircraft are allowed at or in front of the flight line. Intentional flying behind the flight line is prohibited.

- 4) I will operate my model using only radio control frequencies currently allowed by the Federal Communications Commission. (Only properly licensed Amateurs are authorized to operate equipment on Amateur Band frequencies.)
- 5) Flying sites separated by three miles or more are considered safe from site-to-site interference, even when both sites use the same frequencies. Any circumstances under three miles separation require a frequency management arrangement, which may be either an allocation of specific frequencies for each site or testing to determine that freedom from interference exists. Allocation plans or interference test reports shall be signed by the parties involved and provided to AMA Headquarters.

Documents of agreement and reports may exist between (1) two or more AMA Chartered Clubs, (2) AMA clubs and individual AMA members not associated with AMA Clubs, or (3) two or more individual AMA members.

- 6) For Combat, distance between combat engagement line and spectator line will be 500 feet per cubic inch of engine displacement. (Example: .40 engine = 200 feet.); electric motors will be based on equivalent combustion engine size. Additional safety requirements will be per the RC Combat section of the current Competition Regulations.
- 7) At air shows or model flying demonstrations, a single straight line must be established, one side of which is for flying, with the other side for spectators.
- 8) With the exception of events flown under AMA Competition rules, after launch, except for pilots or helpers being used, no powered model may be flown closer than 25 feet to any person.
- 9) Under no circumstances may a pilot or other person touch a powered model in flight.

